

Optimization of the Operating Conditions of a Roll-Type Tribo-Electrostatic Separator Using Design of Experiments Methodology

Ahlem BENABDERRAHMANE^{1,2}, Amar TILMATINE¹, Richard GONTRAN², Ana Maria DELISOR³, Thami ZEGHLOUL², Lucian DASCALESCU²

¹APELEC laboratory, Djillali Liabes University of Sidi Bel Abbès, Algeria

²PPRIME Institute, University of Poitiers, Angoulême, France

³University of Pitești, Romania

E-mail : atilmatine@gmail.com ; Lucian.dascalescu@univ-poitiers.fr

Abstract - The aim of the present work is to optimize the operation of the equipment composed of a tribo-charging device associated with a roll-type electrostatic separator. Experimental design methodology was employed to determine the optimum values of the three control variables of the process, which are: the inclination angle of the high-voltage electrode, the applied voltage and the charging duration. The experiments were performed with mm-size particles of Polypropylene (PP) and High Impact Polystyrene (HIPS) originated from industrial waste. High separation efficiency (> 92%) was obtained in terms of both recovery and purity.

Keywords - Electrostatic Separator; Granular Materials; Tribo-electricity; Experimental Design Methodology.

I. INTRODUCTION

In the recent decades, the world has witnessed rapid increase in plastic production. As a consequence, the plastic wastes processing has become a great public concern [1].

In order to contribute to the protection of the environment, the research and development efforts are focused on the development of effective dry technologies for recycling this class of granular wastes [2-4].

Tribo-electrostatic separation is a low-pollution, low-cost, high-efficiency process for recovering the various constituents of granular plastic wastes. This class of separation techniques is capable to process a relatively wide range of particle sizes, using a two-step scheme: tribo-charging of the granular mixture, followed by the selective sorting of the constituents under the action of the electric field forces [5].

Unlike corona or inductive charging, which require external charge sources [6]; tribo-charging occurs when two different materials exchange electric charges by particle-particle and particle-wall impacts. Electron, ion or material transfer between the bodies in contact may explain this charging process [7-11].

The tribo-charged granules are then sorted in either roll-type or free-fall electrostatic separators [12, 13].

The aim of the present work is to evaluate the efficiency of a new compact tribo-electrostatic separation equipment in the selective charging and sorting of granular plastic mixture originating from industrial waste. The study was performed using mm-size granular mixtures composed of Polypropylene (PP) and High Impact Polystyrene (HIPS). The separation process was achieved by two steps: first, the particles get tribo-charged by means of an original inclined-rotating-cylinder-type tribo-charging device, then a roll-type electrostatic separator was employed for the selective sorting of the charged particles. The modeling and optimization of the tribo-electrostatic separator was performed using the experimental design methodology [14].

II. MATERIALS AND METHOD

Experiments were carried out using 100 g samples of a granular plastic mixture containing in equal proportion orange PP and black HIPS, which originated from waste electric and electronic equipment. The materials were provided by APR2, a French company specialized in plastic recycling.

The granule size for both materials ranged between 1 mm and 4 mm (Fig. 1).

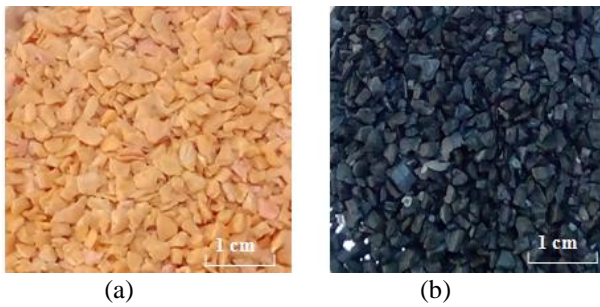

Fig. 1. Aspect and size of PP (a) and HIPS (b) particles

The study was performed using a roll-type tribo-electrostatic separator provided by PRODECOLOGIA Company (Ukraine). The equipment combines a tribo-charging device and an electrostatic separator (Fig. 2 and Fig. 3).

The experiments start by introducing the particles into the tribo-charging device, which consists of an inclined metallic cylinder provided with a coaxial rotating shaft in which are fixed two blades made of Polyurethane. The rotation of the blades generates the tribo-charging of the granular material by repeated particle-to-blade, and particle-to-wall contacts.

When the tribo-charging process is considered to be completed, the hatch is opened up so that the positively- and negatively-charged particles be evacuated and deposited on the vibratory feeder that will then transport them as a monolayer on the surface of the grounded rotating electrode. Once the charged particles enter the electric field zone generated by the high-voltage electrode connected to a reversible power supply, they behave differently according to their polarity : they are either attracted by the electrode and recovered in compartment B1 of the collector, or pinned to the surface of the roll electrode and accumulated in compartments B2 and B3 reserved for middling product.

In the experiments described in the present paper, the high-voltage electrode was connected to a positive polarity DC power supply. The negatively-tribocharged PP particles were attracted to the high-voltage electrode and collected in compartment B1, while most of the positively-tribocharged HIPS particles were pinned to the surface of the grounded roll electrode and collected in compartment B2. A middling product, composed of PP particles that bounced back after an impact with the high-voltage electrode and HIPS particles that were brushed from

the surface of the roll electrode, was collected in compartment B3.

Experimental design methodology was employed for modeling the process. The inclination angle of the HV electrode α [°], the applied voltage U [kV] and the charging duration t [min] were the three control variables under investigation, while the output responses considered in this work were the recovery and the purity of ABS and HIPS products.

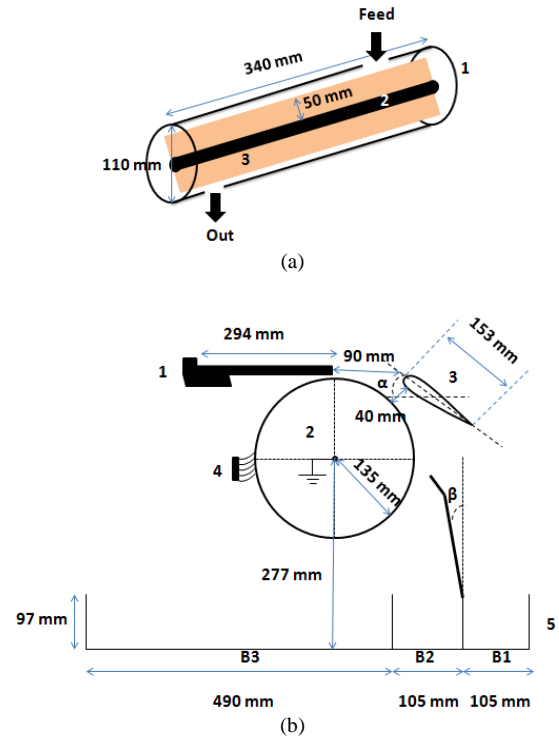

Fig. 2. Schematic representation of the tribo-electrostatic separation installation : (a) Tribo-charging device : 1. Metallic pipe; 2. Rotating shaft; 3. Blade; (b) Roll-type electrostatic separator: 1. Vibratory electromagnetic feeder; 2. Grounded electrode; 3. High-voltage electrode; 4. Brush; 5. Three-compartment collector.



Fig. 3. Photography of the tribo-electrostatic roll-type separator: 1. Tribo-charging device; 2. Vibratory electromagnetic feeder; 3. Grounded electrode; 4. High-voltage electrode; 5. Three-compartment collector.

The recovery and purity of the PP product were calculated as follows :

$$RecPP = \frac{m_{PP B1}}{m_{PP B1} + m_{PP B2} + m_{PP B3}} \times 100 \quad (1)$$

$$PurPP = \frac{m_{PP B1}}{m_{T B1}} \times 100 \quad (2)$$

where $m_{pp B_i}$ correspond to the mass of PP collected in the compartment B_i , and $m_{T B1}$ is the total mass of the compartment B1.

Similar formulas are used to calculate the recovery and purity of HIPS product, mainly collected in compartment B2.

Based on the results of preliminary separation tests, the splitter position $\beta = -10^\circ$, the roll speed $n = 40$ rpm and the feed rate $Q = 2.5$ g/s were kept constant, while the variation domain for each factor under study was established as shown in Table 1.

Table 1. Variation domains of the three control variables

Levels	α [°]	U [kV]	t [min]
-1	15	15	2
0	25	20	4
1	35	25	6

The study was conducted using the experimental design methodology [14, 15], which enabled the derivation of a quadratic model of each output variable y , as function of the three control factors U , t , α :

$$y = a_0 + a_1U + a_2t + a_3\alpha + a_{11}U^2 + a_{22}t^2 + a_{33}\alpha^2 + a_{12}U*t + a_{13}U*\alpha + a_{23}t*\alpha \quad (3)$$

The experimental data were analyzed with MODDE 5.0 software (developed by Umetrics, Sweden) [16], which calculated the coefficients a_i of the model, drew the response contours, and identified the best adjustments of the parameters for optimizing the process. Moreover, the program calculated two statistical criteria: the goodness of fit (R^2) and the goodness of prediction (Q^2) [17].

III. RESULTS AND DISCUSSION

All the experiments were performed at stable climatic conditions, at temperatures ranging between 17°C and 17.8°C and ambient relative humidity that varied between 36.9% and 37.4%.

As predicted, in the tribo-charging device, with the rotary blades that entrained the PP-HIPS mixture in a

turbulent motion, most of the PP particles got charged negatively and were recovered in compartment 1, while most of the HIPS particles got charged positively and were collected in compartment 2.

The results of the central composite face-centered (CCF) experimental design carried out with 50% PP-50% HIPS samples are given in Table 2.

Table 2. Results of the CCF experimental design

Voltage U [kV]	Time t [min]	Angle α [°]	Compartment B1 (PP product)		Compartment B2 (HIPS product)	
			REC PP [%]	PUR PP [%]	REC HIPS [%]	PUR HIPS [%]
15	2	15	81.0	85.3	85.5	82.3
25	2	15	99.4	81.2	78.0	99.8
15	6	15	88.3	89.0	88.0	88.8
25	6	15	98.17	83.5	79.5	98.5
15	2	35	32.2	87.8	94.5	52.7
25	2	35	81.7	84.0	83.6	82.6
15	6	35	56.7	97.6	97.4	69.8
25	6	35	98.2	92.9	86.6	98.9
15	4	25	67.6	91.5	93.1	74.7
25	4	25	96.3	87.0	83.3	96.4
20	2	25	72.9	81.3	83.3	79.0
20	6	25	89.9	87.0	85.4	90.3
20	4	15	97.8	86.0	83.3	98.4
20	4	35	78.0	91.6	91.6	81.6
20	4	25	93.2	88.0	87.6	91.8
20	4	25	87.4	87.8	87.0	87.9
20	4	25	94.1	88.0	88.3	91.6

Table 3 summarizes the values of the statistical criteria of fit goodness (R^2) and prediction goodness (Q^2) estimated for the four models calculated by MODDE5.0 software.

Table 3. The values of the coefficients, R^2 and Q^2 of the responses.

coefficient s	Rec PP [%]	Pur PP [%]	Rec HIPS [%]	Pur HIPS [%]
Q^2	92.7	98.7	97.1	92
R^2	98.2	99.7	99.4	99

$$RecPP = 89.01 + 14.79U + 6.39t - 11.79\alpha - 5.70t^2 + 7.85U*\alpha + 4.35t*\alpha \quad (4)$$

$$PurPP = 87.64 - 2.27U + 3.03t + 2.87\alpha + 1.28U^2 - 3.26t^2 + 1.39\alpha^2 - 0.30U*t + 1.61t*\alpha \quad (5)$$

$$RecHIPS = 87.20 - 4.75U + 1.2t + 3.93\alpha + 1.30U^2 - 2.53t^2 - 0.71U*\alpha \quad (6)$$

$$PurHIPS = 89.34 + 10.78U + 5.01t - 8.22\alpha - 2.99U^2 - 3.86t^2 + 3.98U*\alpha + 3.52t*\alpha \quad (7)$$

Figures 4, 5, 6 and 7 show that the applied high voltage influences strongly the recovery of PP and purity of HIPS, when increasing the high voltage, both recovery of PP and purity of HIPS reach high values. In fact when operating at high value of the applied high voltage, the purity of PP is less than 95%, the same case for the purity of HIPS that does not exceed 83% which means that the electric field generated becomes strong enough to drive to the Box 1 not only PP particles but also some of HIPS particles.

Quite similar curves are obtained for the effect of charging duration on the four responses. Purity and recovery of the two products increase with the increase of the tribo-charging duration and remain constant after $t = 4$ min.

Fig. 8 shows that the inclination angle of the high voltage electrode has a positive effect on the purity of PP product, and the recovery of HIPS product.

According to MODDE 5.0 the optimal operation conditions of the process are: $U = 25$ kV, $t = 5$ min 20 sec and $\alpha = 35^\circ$ for which the predicted values of the purity and recovery of the separated products are:

RecPP = 98.72%, PurPP = 93.04%, RecHIPS = 87.42%, PurHIPS = 97.51%.

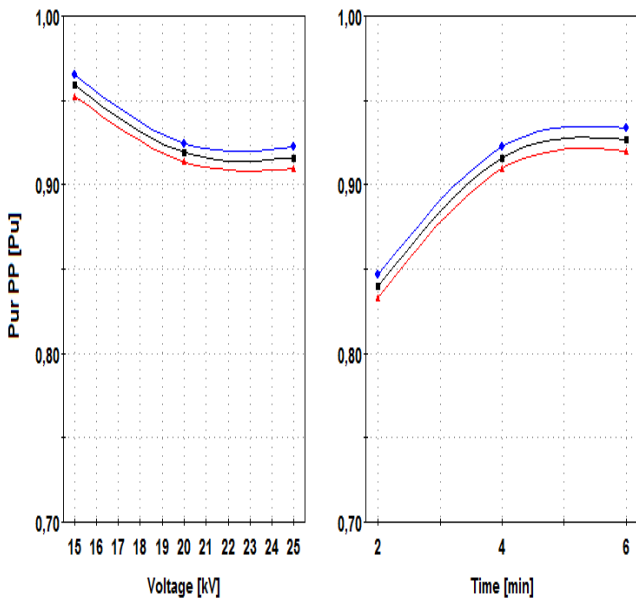

Fig. 4. MODDE 5.0 predicted purity of PP (Polypropylene) product as function of the high voltage, and the charging duration.

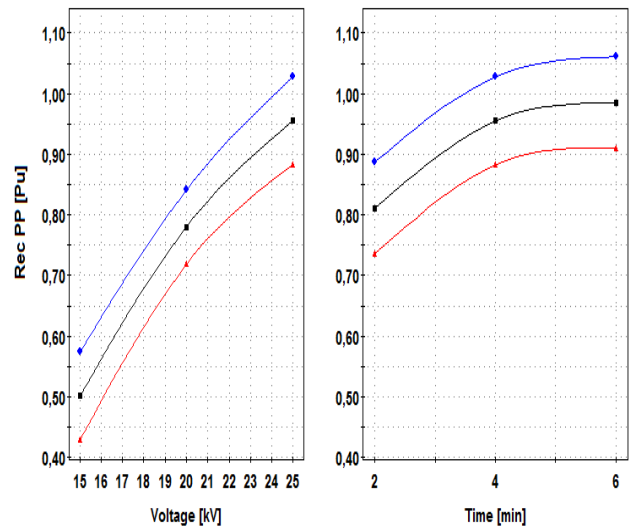

Fig. 5. MODDE 5.0 predicted recovery of PP product as function of the high voltage, and the charging duration.

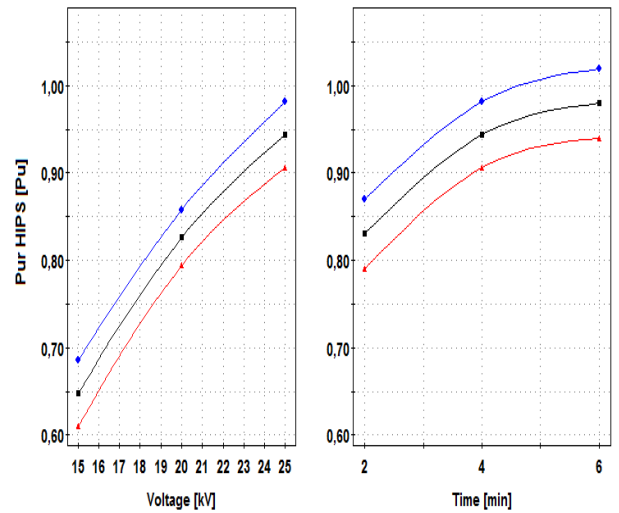

Fig. 6. MODDE 5.0 predicted purity of HIPS (High Impact Polystyrene) product as function of the high voltage, and the charging duration.

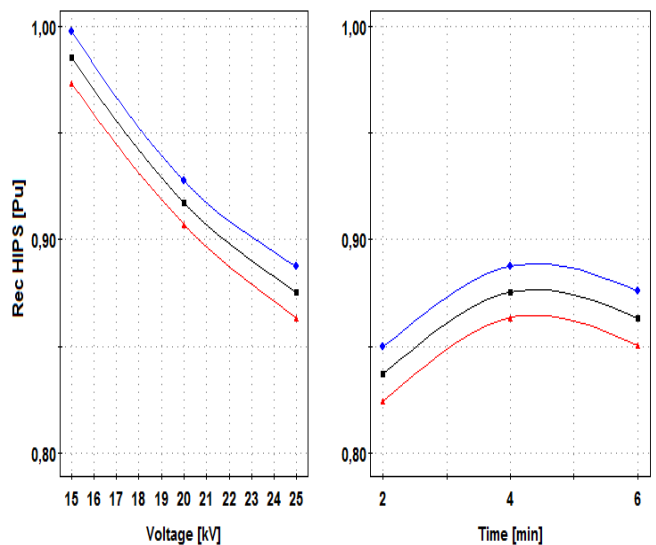

Fig. 7. MODDE 5.0 predicted recovery of HIPS product as function of the high voltage, and the charging duration.

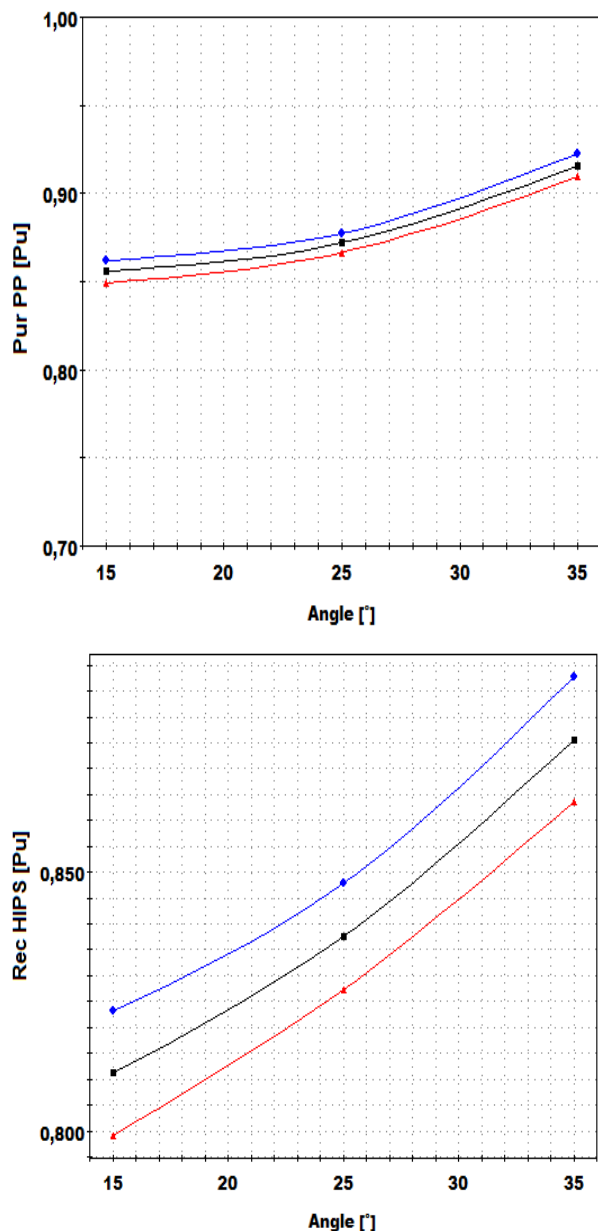

Fig. 8. MODDE 5.0 predicted purity of PP and recovery of HIPS products as function of the inclination angle.

IV. CONCLUSION

The work presented in this paper confirms that the constituents of a granular mixture of plastic wastes can be effectively sorted using a compact tribo-electrostatic equipment. The key advantage of this equipment is that its design facilitates the industry application, as it combines in one unit a tribo-charging device and a roll-type electrostatic separator.

Moreover, the tribo-charging device is characterized by its mechanical simplicity and low power requirements compared to other charging devices, like fluidized beds [18, 19] or vibrating tables [20, 21], for example.

Experimental design methodology enabled the evaluation of the effects of the three control variables,

and the determination of the optimal operation conditions. The efficiency of the separation depends on the electrode configuration as well as the high voltage applied. However, the intensity of the electric field generated by the electrodes strongly affects the trajectories of HIPS particles and may deteriorate the outcome of the separation.

V. ACKNOWLEDGMENT

TASSILI project, jointly sponsored by the Algerian and French Governments, awarded the first author a 3 months Ph-D scholarship at the PPRIME Institute, in Angoulême, France. Another author (Anna Maria Delisor) benefitted of a Dipl.-Eng ERASMUS scholarship, from behalf of European Union. The authors also acknowledge with thanks the support of PRODECOLOGIA Company, which provided the equipment on which the experiments were carried out.

VI. REFERENCES

- [1] G. Wu, J. Li, Z. Xu, "Triboelectrostatic separation for granular plastic waste recycling: A review," *Waste Management*, vol. 33, pp. 585–597, 2013.
- [2] A. Tilmatine, K. Medles, M. Younes, A. Bendaoud, L. Dascalescu, "Roll-type versus free-fall electrostatic separation of tribocharged plastic particles," *IEEE transactions on industry applications*, vol. 46, 2010.
- [3] L. Dascalescu, R. Morar, A. Iuga, A. Samuila, V. Neamtu, "Electrostatic separation of insulating and conductive particles from granular mixes," *Particulate Sci. Technol.*, vol. 16, pp. 25–42, 1998.
- [4] I. I. Incullet, G. S. P. Castle, J. D. Brown, "Electrostatic separation of plastics for recycling," *Particulate Sci. Technol.*, vol. 16, pp. 91–100, 1998.
- [5] G. Dodbiba, A. Shibayama, T. Miyazaki, T. Fujita, "Triboelectrostatic separation of ABS, PS and PP plastic mixture," *Materials Transactions*, Vol. 44, pp. 161 to 166, 2003.
- [6] P. M. Ireland and K. Nicholson, "Analysis and comparison of particle tribochargers," *Minerals Engineering*, vol. 24, pp.914–922, 2011.
- [7] C. H. Park, H. S. Jeon, H. S. Yu, O. H. Han, J. K. Park, "Application of electrostatic separation to the recycling of plastic wastes: separation of PVC, PET, and ABS," *Environ. Sci. Technol.*, vol. 42, pp. 249–255, 2008.
- [8] M. Lungu, "Electrical separation of plastic materials using the triboelectric effect," *Minerals Engineering*, vol.17, pp. 69–75, 2004
- [9] E. G. Kelly, D. J. Sottiswood, "The theory of electrostatic 2, separations: a review, part 1. Fundamentals," *Minerals Engineering*, pp. 33–46, 1989.
- [10] G. S. P. Castle, "Contact charging between insulators," *Journal of Electrostatics*, vol. 40–41, pp. 13–20, 1997.
- [11] J. Lowell, A. C. Rose-Innes, "Contact Electrification," *Adv. Phys.*, vol. 29, 947–1023, 1980.
- [12] M. Xue, J. Li, Z. Xu, "Management strategies on the industrialization road of state-of-the-art technologies for e-waste recycling: the case study of electrostatic separation: a review," *Waste Management & Research*, Vol. 31, pp.130–140, 2013.

- [13] O. C. Ralston, "Electrostatic separation of mixed granular solids," Amsterdam, New York: Elsevier Pub. Co., 1961.
- [14] L. Eriksson, E. Johansson, N. Kettaneh-Wold, C. Wikström, and S. Wold, "Design of Experiments. Principles and Applications," Stockholm, Sweden: Learnways AB, 2000.
- [15] N. L. Frigon and D. Mathews, Practical Guide to Experimental Design New York: Willey, 1996.
- [16] MODDE 5.0 User Guide and Tutorial, Umetrics AB, Umea, Sweden, 1999
- [17] M. Miloudi, K. Medles, A. Tilmatine, A. Bendaoud, L. Dascalescu, "Optimization of belt-type electrostatic separation of triboaerodynamically charged granular plastic mixtures," IEEE Transactions on Industry Applications, vol. 49, pp. 1781-1786, 2013.
- [18] A. Iuga, L. Calin, V. Neamtu, A. Mihalcioiu, L. Dascalescu, "Tribocharging of plastics granulates in a fluidized bed device," Journal of Electrostatics, Vol. 63, pp. 937-942, 2005.
- [19] L. Calin, A. Mihalcioiu, A. Iuga, and L. Dascalescu, "Fluidized bed device for plastic granules triboelectrification," Part. Sci. Technol., Vol. 25, pp. 205-211, 2007.
- [20] L. Dascalescu, A. Urs, S. Bente, M. Huzau, and A. Samuila, "Charging of mm-size insulating particles in vibratory devices," Journal of Electrostatics, Vol. 63, pp. 705-710, 2005.
- [21] M. Blajan, R. Beleca, A. Iuga, and L. Dascalescu, "Triboelectrification of granular plastic wastes in vibrated zigzag shaped square pipes in view of electrostatic separation," IEEE transactions on industry applications, Vol. 46, pp. 1558-1563, 2010.