

# Study of the performance of a refrigeration cycle without and with ejector using ternary azeotropic refrigerants

Y. Maalem<sup>a\*</sup>, A. Zerfa<sup>a,b</sup>, M. Mehemmai<sup>a</sup>, H. Madani<sup>a</sup> and S. Fedali<sup>a</sup>

<sup>a</sup>LESEI, Faculty of Technology, University of Batna 2, 05000 Batna, Algeria

<sup>b</sup>LCIP, Faculty of science and Technology, University of Khenchela, 040000 Khenchela, Algeria

\*Corresponding author, email: y.maalem@univ-batna2.dz

Selected paper of Geclerec-2022, Received date: Jan 10, 2022 ; accepted date: Apr. 5, 2022

## Abstract

This work presents an energy analysis of an operating cycle of a conventional refrigerating machine without and with ejector using ternary azeotropic mixtures as refrigerants with the refrigerant R134a, the mixtures considered in this study are: R600a+R1234ze+R13II, R134a+R1234yf+R600a and R134a+RE170+R600a. A numerical simulation was carried out to evaluate and compare the energy performance of these mixtures with the R134a refrigerant, in particular the determination of the coefficient of performance (COP). The comparison was made for evaporation temperatures ( $T_e$ ) between (-10 and 10) °C and condensation temperatures ( $T_c$ ) between (30 and 55) °C. The results obtained show in particular that the refrigeration system with ejector allows an increase in COP greater than 5.07% compared to that of the conventional refrigeration system and that the performance obtained with the ternary azeotrope mixture R134a+RE170+R600a offers the maximum values of COP compared to the other mixtures (R600a+R1234ze+R13II and R134a+R1234yf+R600a) as well as the refrigerant R134a in the two cycles studied.

**Keywords:** Ternary refrigerants; Conventional cycle; Ejector; Entrainment ratio; COP

## 1. Introduction

Among the greatest challenges that the refrigeration field faces today is the energy saving of conventional vapor compression refrigeration systems and on the other hand, on the improvement of the performance of these systems by various modifications of the cycles. In this context, several solutions have been proposed by various researchers to improve the energy efficiency of vapor compression refrigeration systems. Among these is the incorporation of an ejector as a trigger [1-2]. In fact, ejector refrigeration cycles can be a promising alternative to conventional refrigeration systems, where several research works have been carried out in recent years on these systems with different fluids, where they have proven that the use of this element makes it possible to bring a marked improvement in the coefficient of performance of the conventional refrigeration machine. The first study on the ejector refrigeration cycle was proposed by Kornhauser [3], it was found that the ejector cycle has great potential for significant improvement over a conventional refrigeration system. In his study, seven refrigerants were studied: R11, R113, R114, R500, R502, R22 and R717, the results showed that the coefficient of performance of R502 in the refrigeration system with ejector was improved by up to 30% compared to the conventional system. Nehdi et al [4] carried out a comparison of several synthetic refrigerants in a basic cycle without and with ejector, it was found that R141b gives maximum performance, where the COP has been improved by up to 20%. In another study,

Sarkar [5] did a theoretical study on the performance of three natural refrigerants in an ejector refrigeration cycle, the results showed that a maximum improvement in system performance was obtained in the case of the isobutane, while the minimum performance improvement was achieved for ammonia. In the study by Disawas and Wongwiset [6], the authors experimented and analyzed a conventional refrigeration installation compared to a refrigeration system with ejector, the only difference between the two systems was the inclusion of an ejector, it was found that the presence of the ejector in the cycle triggered an increase in COP and at the same time, a decrease in the compressor pressure ratio. A theoretical comparison of the performance of the ejector refrigeration cycle with the conventional refrigeration cycle using R1234yf as refrigerant was carried out by Li et al [7], a COP improvement of 5.9% between both cycles was noted. Zhao et al [8] studied the performance of the ejector refrigeration cycle with the zeotropic mixture (R134a/R143a), the simulated results revealed that the COP obtains a maximum value of 4.18 with a mass fraction of 0.9 and gives a minimum value of 3.66 with a mass fraction of 0.5. Boumaraf et al [9] have proposed and analyzed a modification of a refrigeration system with ejector to overcome the constraints linked to the operation permanent separator and ejector in the basic ejector refrigeration cycle. They studied R134a and R1234yf as refrigerants and concluded that the COP of the new system is higher for R1234yf, especially at high condensing temperatures.

From the review of the literature on improving the performance of ejector refrigeration cycles cited above, it was noted that most studies are focused on performance evaluation with pure refrigerants or binary blends. In the other hand, ternary azeotropic mixtures have not received considerable interest. The objective of our study is the calculation of the coefficient of performance of the vapor compression refrigeration machine without and with ejector using ternary azeotropic mixtures (R600a+R1234ze+R13II, R134a+R1234yf+R600a and R134a+RE170+R600a) [10-11] as refrigerant.

**2. Description of the refrigeration cycles**

Figure 1 shows the diagram of the conventional vapor compression refrigeration system comprising a compressor, a condenser, expansion valve and an evaporator. The operating principle of the cycle is shown in the ph diagram (Figure 1 (b)). The refrigerant vapor compressed at high pressure (P2) is condensed at high temperature (T3) in the condenser (state 3) by heat transfer to the environment. The refrigerant pressure is reduced in the expansion valve. At low pressure (P4) and low temperature (T4), the refrigerant vaporizes, allowing heat to be extracted from the substance to be cooled. To complete the cycle, at the outlet of the evaporator (state 1), the low pressure refrigerant vapor is compressed and brought to high pressure from the compressor.

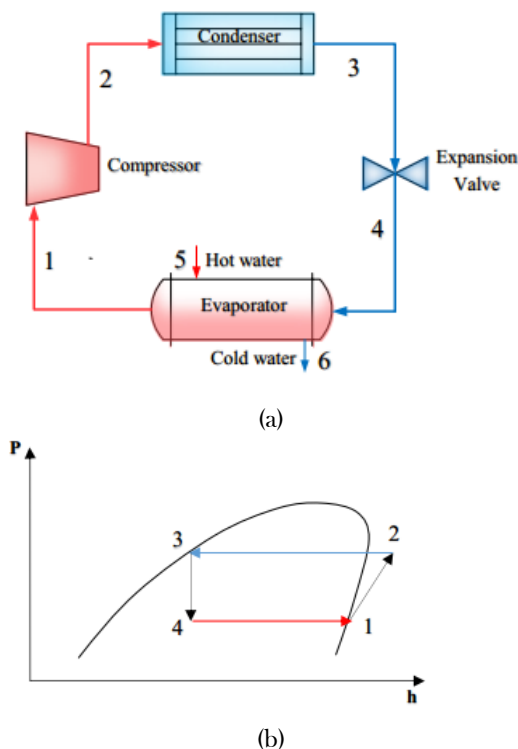

Figure 1. Schematic diagram (a) and P-h diagram (b) of the conventional refrigeration cycle [13]

The compression/ejection refrigeration system (Figure 2) consists of compressor, condenser, evaporator, ejector,

separator and expansion valve. The operating cycle of this system is as follows: the refrigerant in the form of saturated vapor enters the compressor at pressure P1 (state 1) where it is compressed at high pressure to pressure (P2). The refrigerant in the superheated state (state 2) thus obtained is cooled in the condenser to the temperature corresponding to state (3). This constitutes the working fluid (primary fluid) which enters the primary nozzle of the ejector (Figure 2 (a)), then undergoes an expansion in this nozzle. At the outlet (state 4), the primary fluid drives the secondary fluid at lower pressure from the evaporator (state 10). The primary and secondary streams mix in the mixing chamber (state 5). A first pressure increase due to the formation of a right shock wave takes place in the cylindrical part of the mixing chamber followed by a second due to compression in the diffuser.

On leaving the ejector (state 6), the mixture goes to a separator which divides the two phases (liquid-vapor) of the mixture. The saturated vapor in state (1) is sucked by the compressor while the saturated liquid in state (7) passes through an expansion valve before entering the evaporator to produce cold.

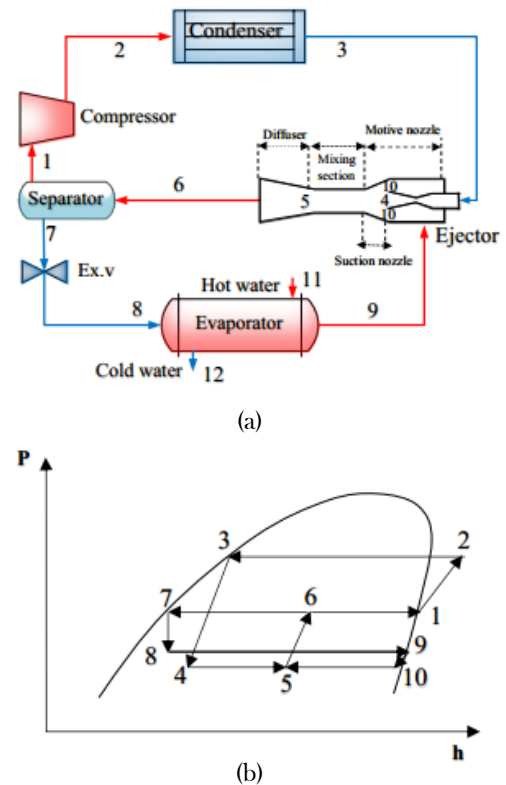

Figure 2. Schematic diagram (a) and P-h diagram (b) of the compression / ejector refrigeration cycle [7]

**3. Cycles modeling**

In this part, a simulation model is developed in order to demonstrate the performance of the above systems. This model makes it possible to calculate the thermodynamic parameters of the refrigerants in the different characteristic points of the refrigeration cycles.

To simplify the analysis of the refrigeration cycles considered, the following assumptions are made [7-8]:

- The flow in the ejector is one-dimensional;
- The speed of the refrigerants entering and leaving the ejector is neglected;
- The primary fluid and the secondary fluid reach the same pressure at the inlet of the section of the mixing chamber;
- The ejector efficiencies remain constant;
- The expansion in the expansion valve is isenthalpic;
- Transformations in heat exchangers are isobaric;
- Pressure drops are negligible in the heat exchangers, the separator and the various pipes;
- The refrigerant conditions at the evaporator and condenser outlets are in a saturated state;
- No heat transfer to the environment, except in the condenser;
- The compressor operates with an appropriate isentropic efficiency value;

Based on the above assumptions, the following equations are established in our simulation model:

### 3.1. Analysis of conventional vapor compression refrigeration system

At the evaporator outlet (state 1): saturated steam

$$h_1 = f(T_e, x = 1) \quad (1)$$

$$s_1 = f(T_e, x = 1) \quad (2)$$

At the condenser outlet (state 3): saturated liquid

$$h_3 = f(T_c, x = 0) \quad (3)$$

$$p_3 = f(T_c, x = 0) \quad (4)$$

At the outlet of the expansion valve (state 4):

$$h_4 = h_3 \quad (5)$$

At the compressor outlet (state 2): superheated steam

$$h_{2is} = f(s_2, p_2) \quad (6)$$

$$h_2 = h_1 + \frac{h_{2is} - h_1}{\eta_{comp}} \quad (7)$$

Isentropic efficiency of compression [14]:

$$\eta_{comp} = 0.874 - 0.00135\pi \quad (8)$$

Compression work:

$$w_{comp} = (h_2 - h_1) \quad (9)$$

The heat removed from the evaporator:

$$q_{evap} = (h_1 - h_4) \quad (10)$$

### 3.2. Analysis of compression/ejection refrigeration system

At the condenser outlet (state 3): saturated liquid

$$h_3 = f(T_c, x = 0) \quad (11)$$

$$p_3 = f(T_c, x = 0) \quad (12)$$

$$s_3 = f(T_c, x = 0) \quad (13)$$

At the evaporator outlet (state 9): saturated steam

$$h_9 = f(T_e, x = 1) \quad (14)$$

$$p_9 = f(T_e, x = 1) \quad (15)$$

$$s_9 = f(T_e, x = 1) \quad (16)$$

The compression / ejection refrigeration cycle analysis is initially linked to that of its main organ, the ejector, which is why we focus our study in this part on this organ. The performance of an ejector is defined by a drive ratio ( $\mu$ ) given by:

$$\mu = \frac{m_s}{m_p} \quad (17)$$

Where  $m_s$  and  $m_p$  are the mass flow rates of the secondary and primary fluid, respectively.

For ejector modeling, adopting the constant pressure mixing model for this study. By applying the conservation equations for mass, momentum and energy we will have [15-16]:

At the outlet of the primary nozzle (state 4):

$$h_4 = h_3 - \eta_{mn} (h_3 - h_{4is}) \quad (18)$$

$$v_4 = \sqrt{2(h_3 - h_4)} \quad (19)$$

$$A_4 = \frac{1}{(1 + \mu)\rho_4 v_4} \quad (20)$$

When the secondary fluid enters the ejector (state 10):

$$h_{10} = h_9 - \eta_{sn}(h_9 - h_{10is}) \quad (21)$$

$$v_{10} = \sqrt{2(h_9 - h_{10})} \quad (22)$$

$$A_{10} = \frac{\mu}{(1 + \mu)\rho_{10}v_{10}} \quad (23)$$

At the mixing chamber (state 5):

$$v_5 = \sqrt{\eta_{mc} \left( \frac{1}{(1 + \mu)} \right)} v_4 + \frac{\mu}{(1 + \mu)} v_{10} \quad (24)$$

$$h_5 = \frac{1}{1 + \mu} \left( h_4 + \frac{v_4^2}{2} \right) + \frac{\mu}{(1 + \mu)} \left( h_{10} + \frac{v_{10}^2}{2} \right) - \frac{v_5^2}{2} \quad (25)$$

At the outlet of the diffuser (state 6):

$$h_6 = h_5 + \frac{v_5^2}{2} \quad (26)$$

$$h_{6is} = h_5 + \eta_d(h_6 - h_5) \quad (27)$$

$$x_6 = \frac{1}{1 + \mu} \quad (28)$$

At the outlet of the expansion valve (state 8):

$$h_8 = h_7 \quad (29)$$

Compression work:

$$w_{comp} = \frac{h_2 - h_1}{1 + \mu} \quad (30)$$

The heat removed from the evaporator:

$$q_{evap} = \frac{\mu(h_9 - h_8)}{1 + \mu} \quad (31)$$

Coefficient of performance (COP) of the two cycles:

$$COP = \frac{q_{evap}}{w_{comp}} \quad (32)$$

The operating conditions [5, 7] adopted for the simulation of the cycles are given in Table 1.

Table1: Operating condition for simulation

Settings	Values
Evaporating temperature, $T_e$	5
Condensing temperature, $T_c$	40
Isentropic efficiency of the primary nozzle, $\eta_p$	85
Isentropic efficiency of the secondary nozzle, $\eta_s$	85
Isentropic efficiency of the mixing chamber, $\eta_{mc}$	95
Isentropic efficiency of the diffuser, $\eta_d$	85

#### 4. Results and discussion

In order to present the results of the numerical simulation obtained from the application of ternary azeotropic mixtures, a validation of the energy model developed previously was carried out. The model of this study was compared with the work of Li et al [7] using refrigerants R134a and R1234yf as working fluid were tested in the case of refrigeration cycle with compression/ejector.

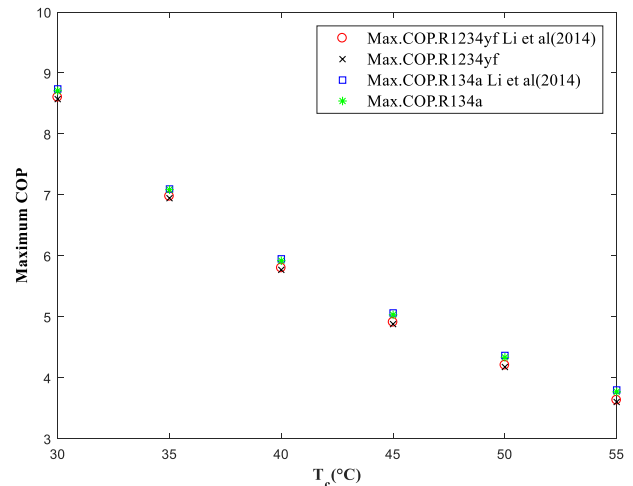

Figure 3. Comparisons of our results with those of the literature by Li et al

Figure 3 shows us a good approach between our results those determined by Li et al. In the following, the influence of condenser temperature and evaporator temperature on the performances of the cycles has been investigated.

##### 4.1. Influence of the variation of the condensing temperature on the performance of the cycles

Figure 4 illustrates the effect of the condensation temperature on the performances of the ternary azeotropic mixtures R600a+R1234ze+R13I1, R134a+ RE170+R600a, R134a+R1234yf+R600a and the pure refrigerant R134a in the case basic refrigeration cycle (BC) as well as the

compression/ejection refrigeration cycle (ERC) respectively.

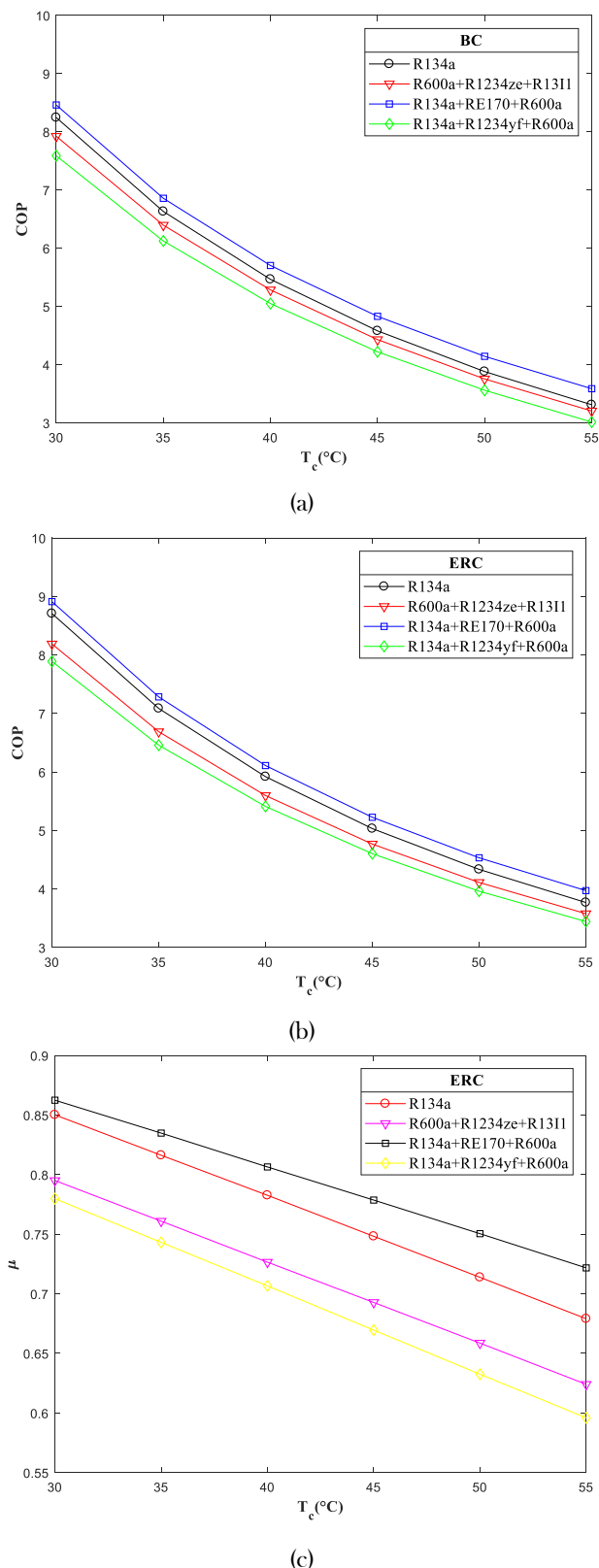

Figure 4. Influence of the variation of the condensing temperature on the performance of the cycles

From the results we can see that the maximum COP values in the two refrigeration cycles (BC and ERC) which use the ternary mixtures (R600a+R1234ze+R131I) and (R134a+R1234yf+R600a) are lower than that obtained with the pure refrigerant R134a, while for the ternary mixture (R134a+RE170+R600a) the value of the COP is higher than that obtained with R134a.

From a performance point of view, we notice that the compression / ejection refrigeration cycle (ERC) presents values of COP higher than those found in the basic cycle (BC) over the entire temperature range studied, this due to the presence of the ejector.

The increase in the temperature at the condenser leads to an increase in the primary flow, which enters the driving nozzle of the ejector, and a decrease in the secondary flow sucked by the latter, which leads to a drop in the drive ratio ( $\mu$ ) and consequently a decrease in the coefficient of performance.

The entrainment ratio is a function of the compressor power, so it directly influences the system COP value.

The COP of R134a+RE170+R600a in (BC) and (ERC) decreases from 8.459 to 3.586 and from 8.911 to 3.971 respectively when the condensing temperature varies from 30 to 55  $^{\circ}\text{C}$ .

#### 4.2. Influence of the variation of the evaporation temperature on the performance of the cycles

Figure 5 illustrates the effect of the evaporation temperature on the performances of the ternary azeotropic mixtures (R600a+R1234ze+R131I, R134a+RE170+R600a, R134a+R1234yf+R600a) and the pure refrigerant R134a for the basic refrigeration cycle (BC) and the compression/ejection refrigeration cycle (ERC) respectively.

It is also noted from the results that the ternary mixture R134a+RE170+R600a has a better COP compared to the other fluids in the compression/ejection refrigeration cycle, which is interpreted that the mixture has the best entrainment ratio ( $\mu$ ).

The COP of the mixture R134a+RE170+R600a in the both systems: (BC) and (ERC) increases from 3.455 to 6.964 and from 3.760 to 7.367 respectively, when the evaporating temperature increases (from -10 to 10  $^{\circ}\text{C}$ ).

Indeed, the increase in the temperature at the level of the evaporator causes an increase in the secondary flow sucked by the ejector and a decrease in the primary flow, which enters the driving nozzle, which leads to an increase in the entrainment ratio ( $\mu$ ) and the consequent increase in the coefficient of performance (COP).

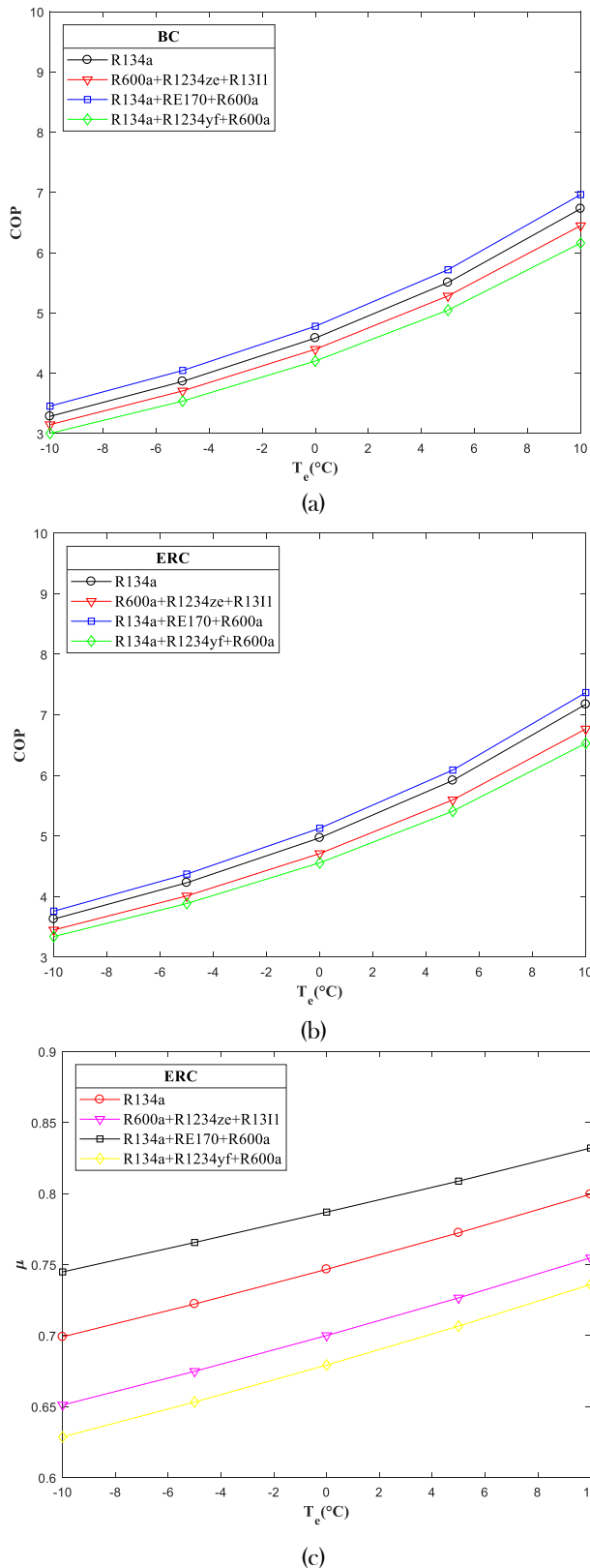

Figure 5. Influence of the variation of the evaporation temperature on the performance of the cycles

### 5. Conclusion

In this study, we evaluated the performance evolution of a vapor compression refrigeration system with and

without ejector using the ternary azeotropic mixtures (R600a+R1234ze+R131I, R134a+RE170+R600a, R134a+R1234yf+R600a) and compared their performance with the refrigerant R134a.

From which we can draw the following conclusions:

- The ejector refrigeration cycle provides much better COP values than those of the conventional vapor compression cycle;
- To achieve high values of the drive ratio, it is better to increase the temperature at the evaporator;
- The best performance of the ejector refrigeration system is achieved when the drive ratio is high;
- Refrigeration cycles operating with the ternary mixture R134a+RE170+R600a have a high COP than other refrigerants.

### Nomenclature

#### Symbols

- $A$  Cross-sectional area,  $m^2$
- $h$  Specific enthalpy,  $kJ\ kg^{-1}$
- $m$  Mass flow rate,  $kg\ s^{-1}$
- $s$  Specific entropy,  $kJ\ kg^{-1}\ K^{-1}$
- $v$  Velocity ( $m\ s^{-1}$ )
- $q$  Cooling capacity,  $kJ\ kg^{-1}$
- $w$  Specific work,  $kJ\ kg^{-1}$
- $T$  Temperature, °C or K
- $P$  Pressure, MPa
- $x$  Vapor quality

#### Greek symbols

- $\mu$  Entrainment ratio
- $\eta$  Efficiency
- $\pi$  Compression ratio

#### Subscripts

- $c$  Condensing process
- $e$  Evaporation process
- $d$  Diffuser
- $comp$  Compressor
- $evap$  Evaporator
- $is$  Isentropic process
- $p$  Primary (motive) nozzle
- $s$  Suction nozzle
- $mc$  Mixing chamber
- $I-10$  Thermodynamic state of refrigerants

#### Abbreviations

- $COP$  Coefficient of performance
- $BC$  Basic cycle
- $ERC$  Ejector refrigeration cycle

### References

- [1] S. Elbel, N. Lawrence, Review of recent developments in advanced ejector technology, International Journal of Refrigeration 62 (2016) 1-18.
- [2] J. Sarkar, Ejector enhanced vapor compression refrigeration and heat pump systems-A review, Renewable and Sustainable Energy Reviews 16 (2012) 6647-6659.

- [3] A. A. Kornhauser, The Use Of An Ejector as Refrigerant Expander. *International Refrigeration and Air Conditioning* 82 (1990)10-19.
- [4] E. Nehdi, L. Kairouani, M. Bouzaina, Performance analysis of the vapour compression cycle using ejector as an expander. *International Journal of energy research* 31 (2007) 364-375.
- [5] J. Sarkar, Performance characteristics of natural-refrigerants- based ejector expansion refrigeration cycles. *Proc. Inst. Mech. Eng. Part A J. Power Energy* 223 (2009) 543-550.
- [6] S. Disawas, S. Wongwises, Experimental investigation on the performance of the refrigeration cycle using a two-phase ejector as an expansion device, *International Journal of Refrigeration*. 27 (2004) 587-594.
- [7] H. Li, F. Cao, X. Bu, L. Wang, X. Wang, Performance characteristics of R1234yf ejector-expansion refrigeration cycle, *Applied Energy* 121(2014) 96-103.
- [8] L. Zhao, X. Yang, S. Deng, H. Li, Z. Yu, Performance analysis of the ejector-expansion refrigeration cycle using zeotropic mixtures, *International Journal of Refrigeration* 57 (2015)197-207.
- [9] L. Boumaraf, P. Haberschill, A. Lallemand, Investigation of a novel ejector expansion refrigeration system using the working fluid R134a and its potential substitute R1234yf, *International Journal of Refrigeration* 45 (2014)148-159.
- [10] Y. Zhao, Z. Li, X. Zhang, X. Wang, X. Dong, B. Gao, M. Gong, J. Shen, Azeotropic refrigerants and its application in vapor compression refrigeration cycle, *International Journal of Refrigeration* 108 (2019)1-13.
- [11] Y. Maalem, A. Zarfa, Y. Tamene, S. Fedali, H. Madani, Prediction of thermodynamic properties of the ternary azeotropic mixtures, *Fluid Phase Equilibria* 517(2020)112613.
- [12] G. Saviano, M. Ferrini, L. Benussi, S. Bianco, D. Piccolo, S. Colafranceschi, J. Kjølbro, A. Sharma, D. Yang, G. Chen, Y. Ban, Q. Li, S. Grassini, M. Parvis, Properties of potential eco-friendly gas replacements for particle detectors in high-energy physics, *Journal of Instrumentation* 13 (2018) P03012-P03012.
- [13] F. Molès, J. Navarro-Esbri, B. Peris, A. Mota-Babiloni, A. Barragan-Cervera, Theoretical energy performance evaluation of different single stage vapours compression refrigeration configurations using R1234yf and R1234ze as working fluids, *International Journal of Refrigeration* 44 (2014)141-151.
- [14] O. Brunin, M. Feidt, B. Hivet. Comparison of the working domains of some compression heat pumps and a compression-absorption heat pump, *International Journal of Refrigeration* 20 (1997) 308-313.
- [15] M. Hassanain, E. Elgendy, M. Fatouh, Ejector expansion refrigeration system: ejector design and performance evaluation, *International Journal of Refrigeration* 58 (2015) 1-13.
- [16] G. Besagni, R. Mereu, F. Inzoli, Ejector refrigeration: A comprehensive review, *Renewable and Sustainable Energy Reviews* 53 (2016) 373-407.