

## Study and optimization of the partial discharges in capacitor model at different temperatures

### Etude et optimisation des décharges partielles dans un modèle de condensateur à différentes températures

Karima Smili<sup>\*1</sup> & Lazhar Herous<sup>1,2</sup>

<sup>1</sup> *Electromecanical Department, Badji Mokhtar University, PO .Box 12, 23000 Annaba, Algeria*

<sup>2</sup> *Electrical Engineering Laboratory, University 8 may 45, P.O.Box 401, 24000, Guelma, Algeria.*

*Soumis le 09/04/2016*

*Révisé le:02/07/2016*

*Accepté le 18/07/2016*

#### ملخص:

في هذا المنشور قمنا بدراسة تجريبية على مكثفات مبللة بغشاء عازل مغذية بتوتر كهربائي عالي متناوب و تحت تأثير درجة الحرارة. مما أمكن من تطور التفريغ الجزئي. استخدامنا منهجية التصاميم التجريبية لدراسة مثل هذه العمليات التي سمحت لنا بتحسين نموذج العملية، بأخذ عين اعتبار عاملين مختلفين حصلنا على نموذج رياضي الذي سمح لنا بالتعرف على المعلمات والتفاعلات الأكثر تأثير مابين ا. العوامل

#### الكلمات المفتاحية:

الانفراغ الجزئي- العازل- بليبروبيلان- المكثفة - فرقة - التحسين- تصميم التجارب.

#### Résumé

Dans cet article, nous présentons un modèle de condensateur tout film imprégné avec du liquide imprégnant non dégazé. Des mesures de décharges partielles (DP) ont été effectuées sur des échantillons sous l'effet de la température. Le procédé de l'évolution des décharges partielles dans un diélectrique mixte est multifactoriel. Les décharges partielles s'évaluent sous l'effet du potentiel initial et la température. Le présent document vise à démontrer l'intérêt d'utiliser la conception de la méthodologie des plans expériences pour l'étude de ces processus, en vue de leur modélisation et l'optimisation. Le résultat obtenu est un modèle mathématique capable d'identifier les paramètres et les interactions entre les facteurs.

**Mots-clés:** décharge partielle, isolation, polypropylène, condensateur, claquage, plan d'expérience, optimisation

#### Abstract

In this paper, the partial discharge on models of all-film capacitors impregnated with liquid impregnating undegased is measured and the effect of temperature was examined. The partial discharge evolution in mixed dielectric is multifactorial process. The initial potential as well as the temperature are known to influence the partial discharge evolution. The present paper aims at demonstrating the interest of using the design of experiments methodology for the study of such processes, in view of their modeling and optimization. The obtained result is a mathematical model capable to identify the parameters and the interactions between factors.

**Keywords:** partial discharge, insulation, polypropylene, capacitors, breakdown, experimental design

\* Corresponding author: karimasmili@yahoo.fr

## 1. INTRODUCTION

The dielectric plays an important role in the manufacture of high voltage electric equipment (cable, transformer, capacitor...). It is often subjected to significant constraints which can contribute to a specific degradation in particular the decrease in the rigidity and also the degradation susceptible to put out of service the isolation material. The dielectric is not only submitted to physical and chemical conditions but also to electrical and mechanical conditions. The most important source of damage sustained by insulation materials constituting insulation subjected to high voltage is probably due to the action of partial discharges. The latter constitute one of the causes leading to life time reduction of high voltage equipment [1].

It has been recognized that the failure of this insulation is related to the presence of partial discharge often in inclusions of solid or mixed insulation systems [2].

The development of electrostatic industry has been accompanied by a growing interest in understanding the phenomena that leads to the breakdown of equipments. Numerous studies have shown that the insulation can be submissive to transitional phenomena causing its progressive deterioration. One of the most important phenomena is the partial discharge [3]. Different characterization techniques and operations of the discharges and their action on the evolution of the materials properties constituting devices sources of these discharges (transformers, capacitors) were used [4, 5, 6, 7]. These techniques are based on different forms of discharges appearances [8].

The partial discharge measurement is considered as a very important tool to estimate the life cycle of electrical devices. This evaluation allows to improve the reliability of high voltage insulation systems.

Studies of faults in power capacitors in impregnated dielectric solid have concluded that the main cause of failure of these devices is the appearance of partial discharges initiated on edges of armatures. These devices can quickly slam if discharges occur continuously during the liquid impregnation. One of the criteria for selecting impregnating liquids is the behavior of gas bubbles when discharges occur.

This work is focused on the study of the evolution of partial discharges in a capacitor model designed from a film of polypropylene (PP) impregnated with a mixture of mono-and dibenzyltoluene (MDBT) known under the trade name Jarylec. This type of insulation must be perfectly degased because of a bubble

located near a zone of strong field which will be the seat of partial discharges.

Among the main functions of the power capacitors used in the transport networks and distribution of electrical energy, the reactive power compensation, the energy storage and harmonics filtering.

The present study is focused on the case when a gaseous cavity is present during the first power and causes many partial discharges depending on the voltage under different temperatures. The work conducted on the evolution of the discharges under different ambient temperatures clearly showed that an increase of the temperature in a volume of dielectric, results in a reduction of the threshold electric field required for the appearance of partial discharges.

In a previous study the experimental results confirm the existence of two regimes of partial discharges and show that the low temperature assists breakdown of capacitors at lower voltage levels [9, 10, 11, 12].

As this is a multifactorial process which interacts several electric and physical variables, the design of experiments (DOE) methodology is used [13,14].

This methodology predicts the number of experiments to be performed according to a well-defined objective, to study several factors simultaneously, to reduce the dispersal connected to the measure, to appreciate the effects of coupling between factors and evaluate the respective influence of factors and their interactions [9, 15].

This method is based on statistical and analytical rules to model the process being studied, to reduce and control the experiment time and detect experimental doubtful points of measure. In the case of this work, the objective is to model and optimize the process of discharges detection according to the initial potential  $V_0$  and the temperature  $T$ .

## 2. EXPERIMENTAL TECHNIQUES

The experimental device of detection and measure of partial discharges is described on figure 1.

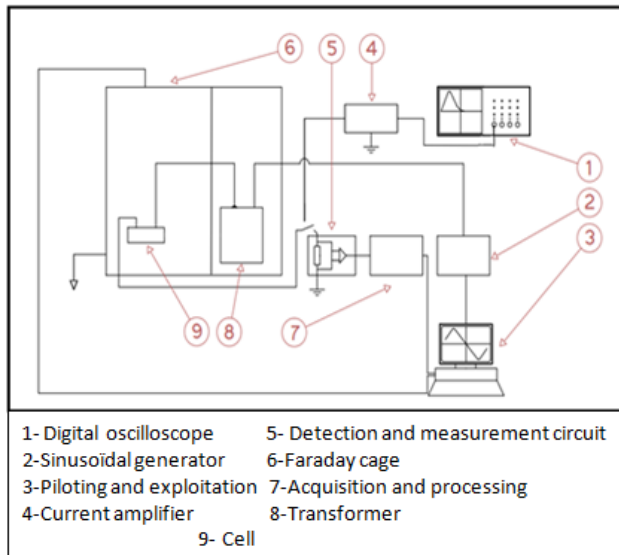

Figure.1. Experimental setup

The measuring cell is placed in a Faraday cage. We apply to these borders permanently a high voltage of effective value ranging between 500 and 5400 volts delivered by a transformer fed by a digital sinusoidal generator.

The acquisitions of Partial Discharges are made every 5 mn. The sensibility of measure is adjusted to limit the number of discharges emerging from chosen measuring range.

An electric detection system with an assembly of current pulses visualization composed from a measuring resistor as is shown in figure 2 a current amplifier and a very high speed oscilloscope. The device also includes a temperature stream room reaching temperatures up to - 40 ° C.

This device allows the measurement of discharge in the order of 0.05 pC with minimum duration between two successive discharges which is 330 ns.

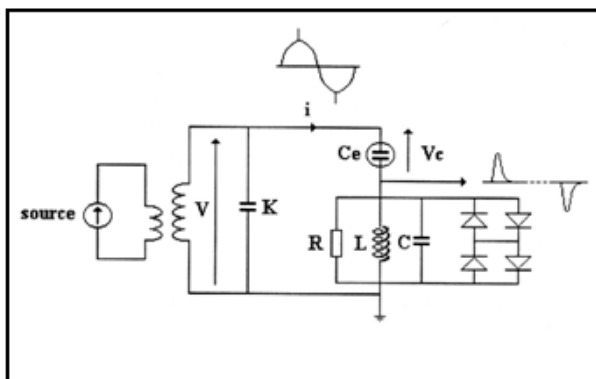

Figure.2. Principe of partial discharge measurement

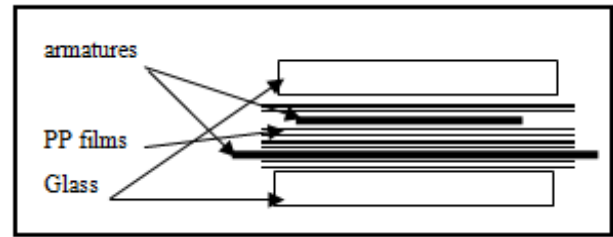

Figure.3. Transverse sectional view

Figure 3 shows the cell of study is a capacitor model of any impregnated film. It consists of a body of plastic material (Teflon), with two ribbons of aluminum arranged at 90° and separated by polypropylene films. The employed cell is filled with a dielectric liquid (Jarylec c100) used in power capacitors. The impregnation has for role to fill any air pockets in order to avoid the dielectric initiation of partial discharges at relatively low voltages.

Partial discharge appearance in the study cell causes current flows through the external circuit. The current circulates in the RLC impedance that allows the suppression of low frequency component of the current  $i$ . The impulses resulting across the impedance have a time constant  $RC = 40ns$ . When a discharge is detected, its amplitude and its polarity as well as the instant of its appearance are measured. The phase of the discharge appearance is deduced from this instant.

In our work, we measured the evolution of the average charge of different discharge, their number and distribution in the phase. The software calculates for each polarity, the statistical quantities. Upon acquisition, a point is displayed on the computer screen every time a discharge is detected at the point of the sine curve that corresponds to the appearance of this discharge.

### 3. EXPERIMENTAL DESIGN METHODOLOGY

In spite of intensive theoretical and experimental research, a partial discharge remains one of the less understood and the most difficult controlled electrostatic phenomena.

Using the experimental design methodology is the way to reduce the number of experiments to be carried out without influencing the quality of the results [16]. The great innovation of this methodology is that it proposes a factorial experimentation, in which the factors investigated vary simultaneously.

The innovation of this methodology is that it proposes a factorial experimentation, in which the factors investigated vary simultaneously. Simple mathematical processing of DOE data enables a rather accurate evaluation of factors

effects and interactions. DOE can also be used to determine the relationship  $f$  between the factors  $x_i, i = 1, \dots, n$  affecting the process and its output  $y$ . The function  $f$  can then be employed for predicting the process optimal operating conditions.

The experiments described hereafter were designed to explore two of the factors that might affect the partial discharge evolution at the models of the capacity designed from impregnated polypropylene films:

- initial potential  $V_0$  [V];
- Low temperature  $T$  [°C];

The mathematical model derived from such a design is a first order polynomial function  $y$  that usually takes into consideration all the two-factor interactions [13, 14].

$$y = f(x_i) = a_0 + \sum a_i x_i + \sum a_{i,j} x_i x_j, \tag{1}$$

$$i = 1 \div 3, j = 1 \div 3, i \neq j$$

For the two factors considered in the present study:  $x_1 = V_0, x_2 = T$ , the linear model is:

$$y = a_0 + a_1 V_0 + a_2 T + a_{12} V_0 T + a_{11} V_0^2 + a_{22} T^2 \tag{2}$$

In the above equation,  $a_0$  is the predicted value of the response  $y$  in the centre of the experimental domain (i.e.,  $u_i = u_{ic} (i = 1, \dots, e)$ , or  $x_i = u_i^* = 0$ ),  $a_i$  estimates the effect of the factor  $x_i$ , and  $a_{i,j}$  quantifies the interaction between the factors  $x_i$  and  $x_j$ . These coefficients can be computed from the measured values of the process response in the conditions prescribed by the composite of experimental design see figure 4 below, using a commercial software MODDE 8.0 (MODELING and DESIGN). [17]

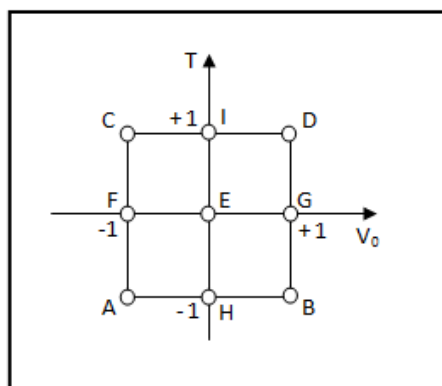

Figure.4. Central composite experimental design for the study of partial discharge evolution

The statistical significance of the coefficients  $a_i$  and  $a_{i,j}$  can be evaluated by calculating the residues  $e_i$ , i.e., the difference between the

experimental value and the one predicted by the model, and then estimating the variance

$$s^2 = \frac{1}{n-p} \sum e_i^2 \tag{3}$$

Where  $n$  is the number of experiments and  $p$  the number of the model coefficients. A coefficient  $a_i$  of the model is statistically significant if it satisfies the Student's  $t$  test

$$t_i = \frac{|a_i|}{s_i} > t_{crit} \tag{4}$$

With  $t_{crit}$  as a function of the degrees of freedom  $(n - p)$ , and

$$s_i^2 = \frac{s^2}{n} \tag{5}$$

The limits of the experiments domain were established:

Potential:  $V_{0min} = 5000 \text{ V}, V_{0max} = 7000 \text{ V}$

Temperature:  $T_{min} = -28^\circ\text{C}, T_{max} = +28^\circ\text{C}$

#### 4. RESULTS

For a given temperature, we apply an increasing tension by steps of about 50 V/s until the threshold of the discharges appearance. For a voltage level (of voltage), we proceed to the acquisition of handling partial discharges for 5mn; the next landing is situated in 200 V over the voltage of partial discharges appearance and we continues to increase up to a voltage close to the breakdown voltage value.

It is noticed that the value of the voltage of partial discharges appearance measured at different temperatures is almost identical and is around 5000 V.

The occurrence of the partial discharges is uncertain which means that the impulse at origin is unidentified. The regime of discharge is variable in time and depending on the voltage. figure 5 shows the appearance of the number of distributions of discharges  $n(\Phi)$  according to the phase registered during the voltage of partial discharges appearance (5000 V) and the other between the transition voltage and the extinction voltage (7000 V).

The graphs representative  $q+$  and  $q-$  show the distribution of the number of discharges in the phase. Each time a discharge is detected at the location of the sinusoid, its amplitude, polarity and the moment of its occurrence are measured, allowing to deduct the discharge phase, therefore, its position on the wave of the voltage. The acquisition of the load distribution determined in phase allows us to count the number of positive and negative charge.

These distributions have almost the same shape from one tension to another and from one temperature to another. It is also noticed a wide distribution of discharges resulting in an increase in the number of discharges due to the formation of a gas bubble which causes the appearance of a burst discharge, leading to the

breakdown state. It is also observed that the discharge appears at the passage by zero of the voltage at the temperature of 28° C, and distribution presenting a peak towards 90° for positive discharges and a peak around 80° for the negative discharges to the voltage of 5000 V.

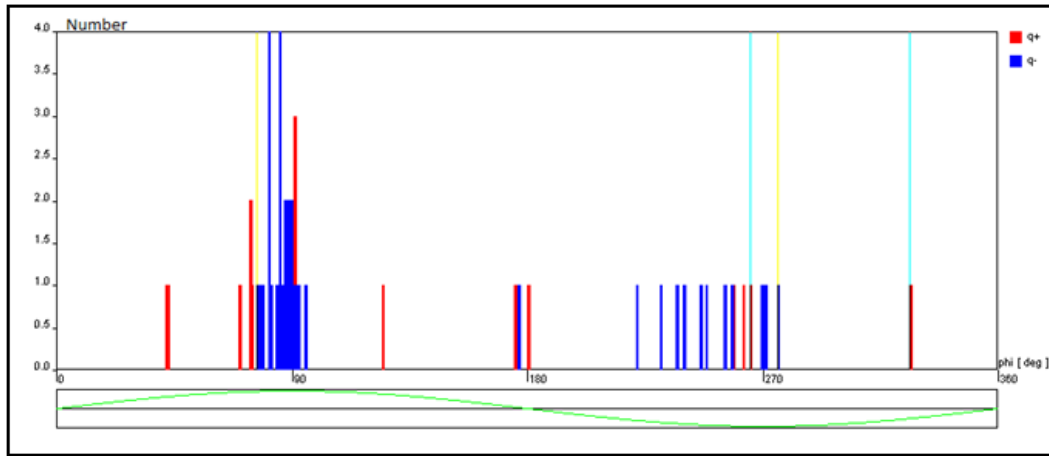

Figure. 5.a Discharges number evolution according to the phase: t = 28°C, V = 5 KV.

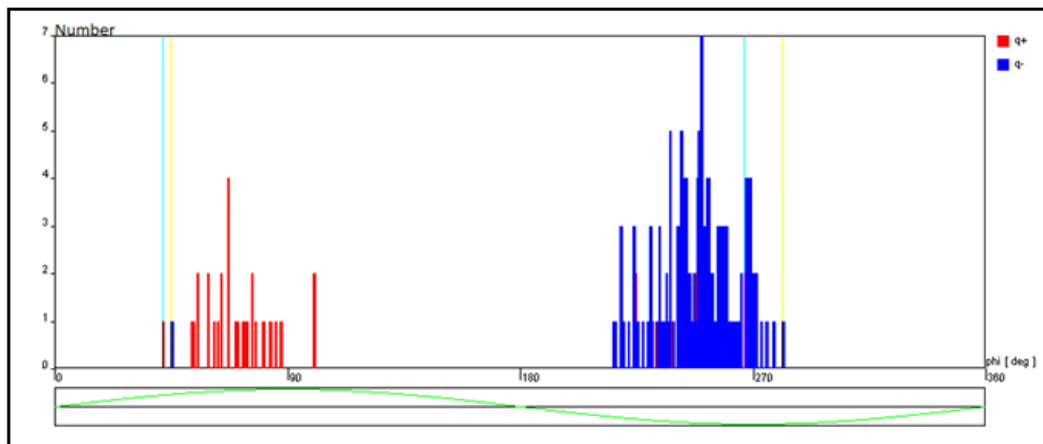

Figure. 5.b Discharges number evolution according to the phase: t = 28°C, V = 7 KV.

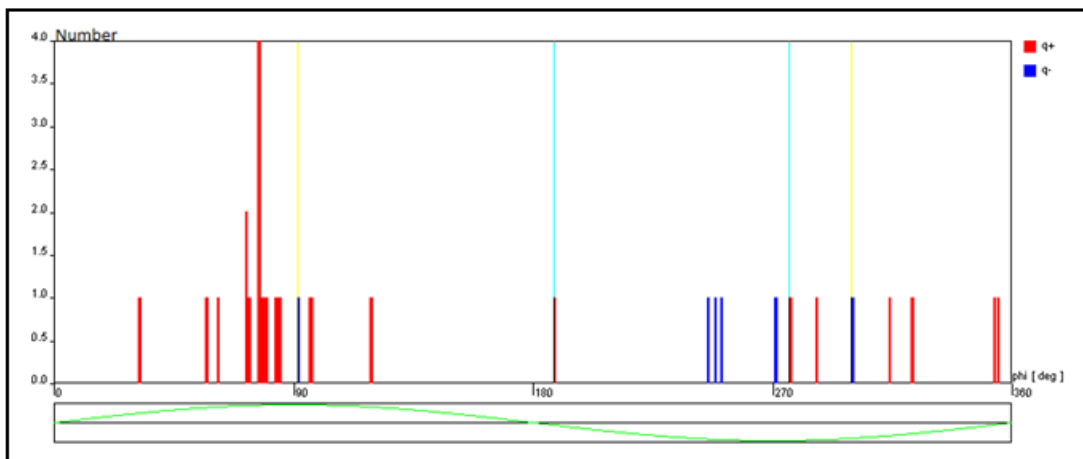

Fig. 5.c Discharges number evolution according to the phase: t = 0°C, V = 5 KV.

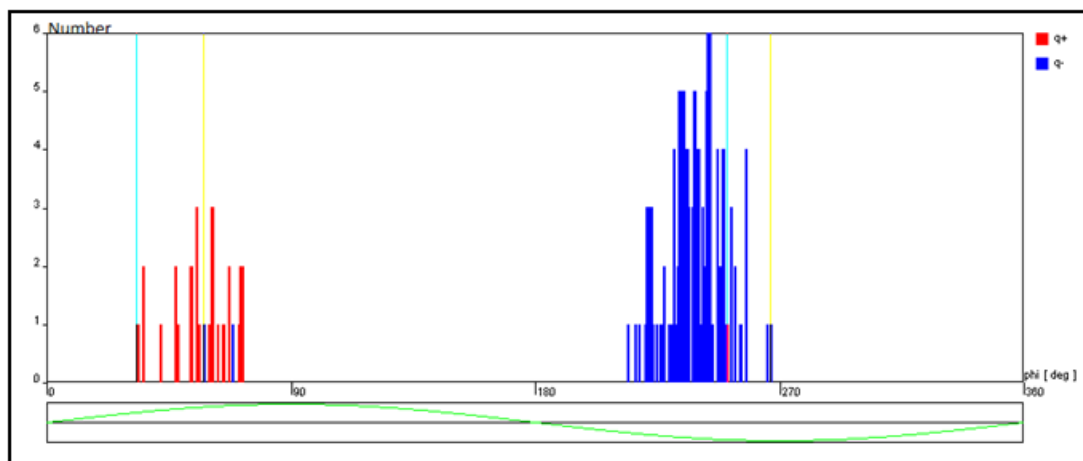

Fig. 5.d Discharges number evolution according to the phase:  $t = 0^{\circ}\text{C}$ ,  $V = 7 \text{ KV}$ .

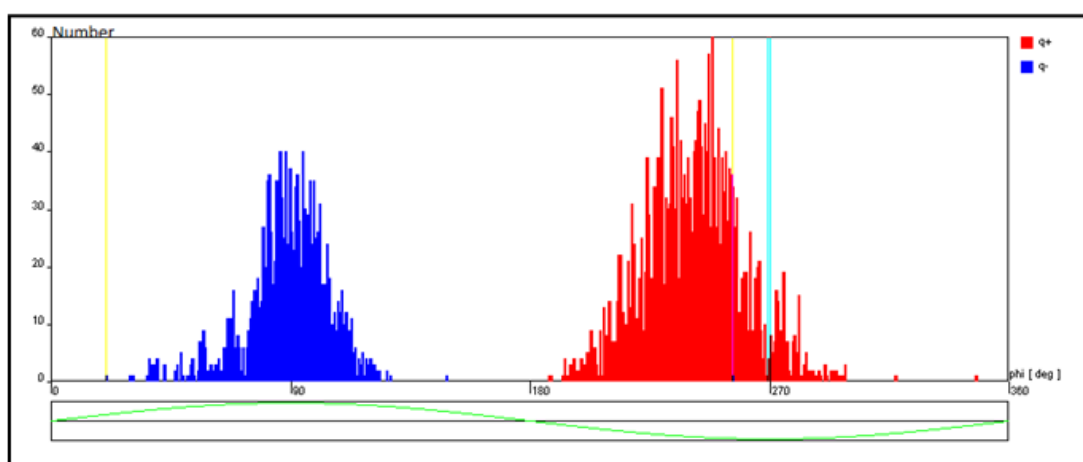

Fig. 5.e Discharges number evolution according to the phase:  $t = -28^{\circ}\text{C}$ ,  $V = 5 \text{ KV}$ .

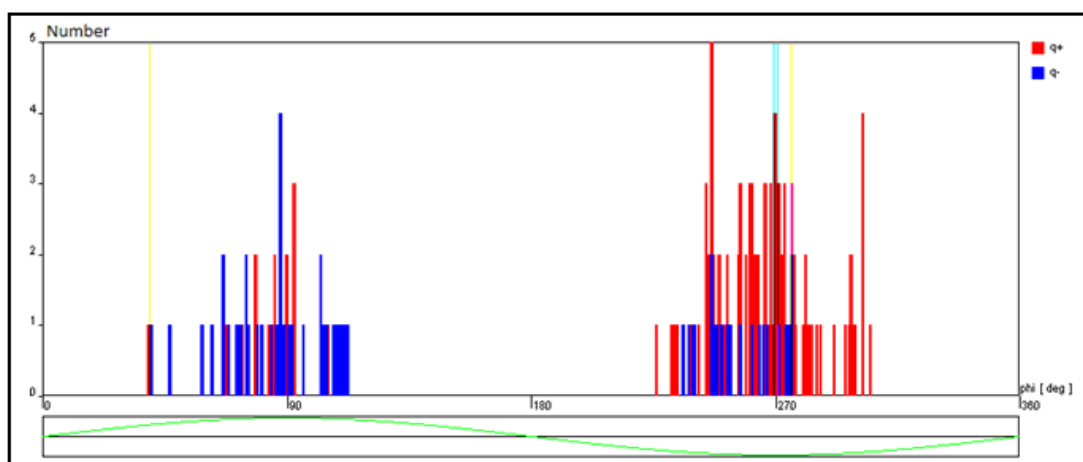

Fig. 5.f Discharges number evolution according to the phase:  $t = -28^{\circ}\text{C}$ ,  $V = 7 \text{ KV}$ .

Figure.5. Discharges number evolution according to the phase for different temperatures

Table 1 presents the rest of the angular distributions of the number of discharges for the entire studied temperature range.

Table 1. Angular position of discharges distributions

T°C	5000 V		7000 V	
	q <sup>+</sup>	q <sup>-</sup>	q <sup>+</sup>	q <sup>-</sup>
28°C	90°	80°	70°	250°
0°C	80°	250°	70°	250°
-28°C	250°	80°	250°	85°

Based on the results of experiments centred composite design illustrated in table 2. the following linear models of the partial discharge evolution are proposed by the responses Y Sum N MODDE 8.0 software:

1	2	3	4	5		
1	Nombre de décharge	Coeff.	SC	Std. Err.	P	Conf. Int(+)
2	Constant	67.4212	20.2462	0.0207775	52.0446	
3	Ten	72.9996	16.1124	0.00622178	41.4183	
4	Temp	-1878.5	16.1124	8.80451e-010	41.4183	
5	Ten*Ten	5.94761	24.7964	0.819964	63.7414	
6	Temp*Temp	1911.45	24.7964	6.96075e-009	63.7414	
7	Ten*Temp	-30.7502	19.7336	0.179908	50.7268	
8						
9						
10		N = 11	Q2 = 0.997	Cond. no. = 3.082		
11		DF = 5	R2 = 1.000	Y-miss = 0		
12			R2 Adj. = 1.000	RSD = 39.47		
13				Conf. lev. = 0.95		

Table 2. Response list: response discharge number

$$SumN = 67.42 + 73V_0 - 1878.5T + 1911.45T^2 \quad (6)$$

The statistical analysis of the data, using Student's test indicates that interaction between the initial potential and temperature and between the initial potential and the initial potential are not significant see table 3 below.

Table 3. Experimental results of composite design center

N°	Factors		Responses
	V <sub>0</sub> (V)	T (°C)	N (number of discharge)

1	5000	-28	3730
2	7000	-28	3986
3	5000	+28	49
4	7000	+28	182
5	5000	0	45
6	7000	0	94
7	6000	-28	3868
8	6000	+28	82
9	6000	0	68
10	6000	0	71
11	6000	0	71

The descriptive quality (R<sub>2</sub>) of Sum N model is equals 0.998, it is find that R<sub>2</sub> is close to 1. It can be said that the resulting model can be used to predict the value of the response.

The predictive quality (Q<sub>2</sub>) is satisfactory and is equal to 0.997. By using the functions of the Sum N response, the software MODDE 8. for the creation and evaluation of statistical design of experiments, gives the predicted response function parameters. Figure 6 shows the iso-response of the voltage according to the temperature. The number of discharge varies inversely with the very low temperatures; it increases with the decreasing temperatures. The number of the maximum discharge for very low temperatures is illustrated by the red zone.

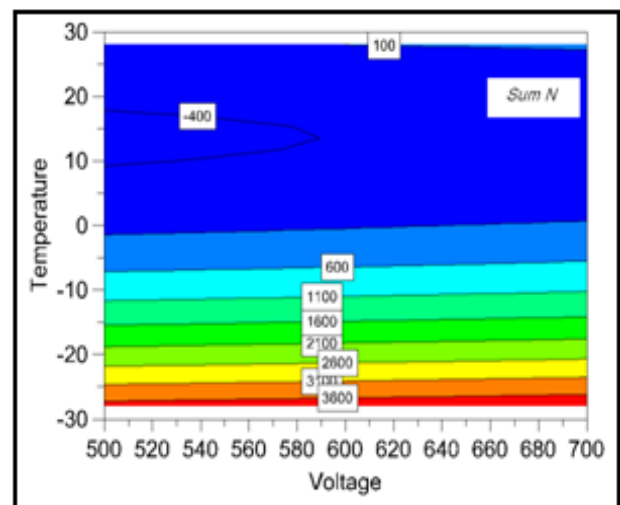

Figure 6. Number of discharge predicted by MODDE 8.0

By using appropriate design of experiments software, it was possible to estimate the effects of these factors and then derive the model of the process. This model (6) served at predicting the optimal set point of the process and can also determine the influence of each factor on the response by drawing the variation of the responses according to Figure 7 and 8.

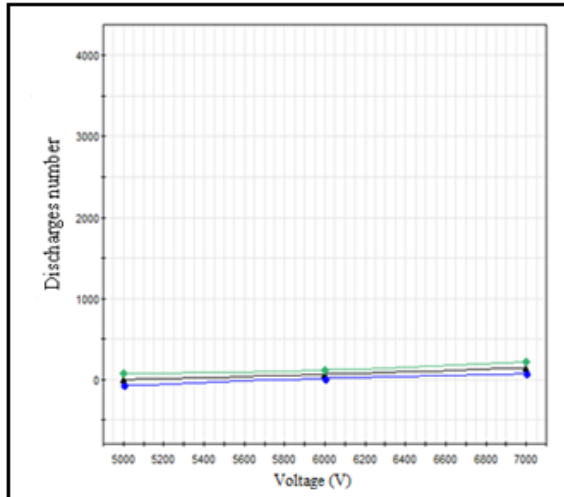

Figure. 7. Predicted response of Sum N factors based on T

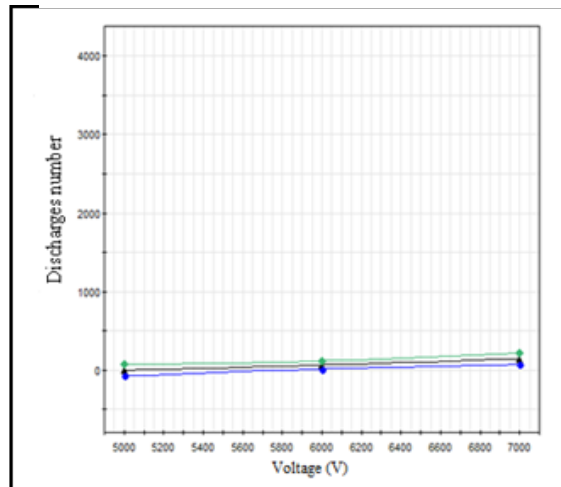

Figure. 8. Predicted response of Sum N factors based on  $V_0$

### 5. DISCUSSION

The regime of discharges is variable in time as a function of voltage and temperature. When one crosses the threshold of priming of the discharges (5 KV), these appear simultaneously on the two half-alternations of the voltage applied for various studied temperatures.

It is observed from Figure 9 the evolution of the average load developed by the partial discharge

according to the voltage applied to different studied temperatures.

The result of comparison between these characteristics shows clearly that the influence of temperature on the apparent charge is not important, for example the average charge pass: 0.49 to 45.76 pC in the temperature 28 °C with a difference of 45.27 pC, the results are completely in accordance with the conductivity-temperature relationship. Indeed, according [8], conductivity in liquids and solids decreases when temperature decreases.

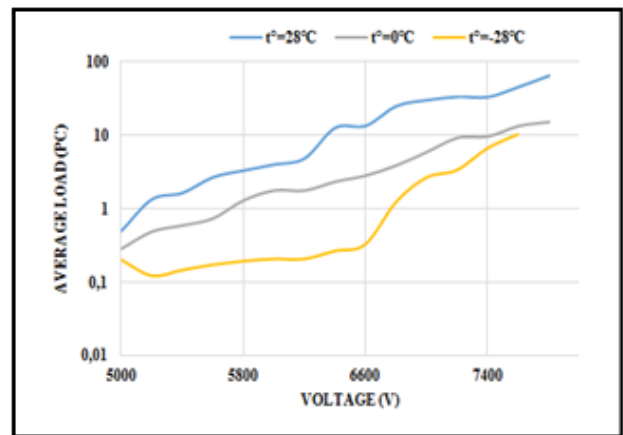

Figure. 9. Evolution of the average charge as a function of voltage

In the previous work [18], it is supposed that the discharges appear in a gaseous cavity in the liquid impregnating.

The results presented have showed that the influence of appearance of the discharge starts when the liquid viscosity increases. Therefore the life of the gaseous cavities formed by these avalanches also increases. In fact, the viscosity Jarylec varies greatly with temperature, for example, the report enters the viscosity of the Jarylec in  $t = -30\text{ }^\circ\text{C}$  and  $t = 20\text{ }^\circ\text{C}$  is equal to 16 [19].

It is noted that the influence of the temperature is translated by the increase of discharge number for increasing the life time of the bubble has the effect of increasing the discharge probability. According to the methodology of experimental design, the important effect suggests that the values of the coefficients associated with the factors in the mathematical models show that the effect of temperature on discharges number is more important than that of the initial potential. Figures 3 and 4 show that in the range  $[0\text{ }^\circ\text{C}$  to



28°C], temperature has no significant influence on the discharge number, on the other hand in the range [-28 ° C to 0 ° C], temperature has an important influence and its decrease increases the number of partial discharges. It may be also noted that the increase in potential accelerates the initial partial discharges number.

## 6. CONCLUSION

The distribution of the number of discharges shows that there are so many positive discharges as negative discharges for different temperatures. By decreasing the temperature, it is noted that the width of the distribution of the discharges increases the probability of appearance of partial discharges increases, which allows to record a greater number of partial discharges when the temperature decreases. The amplitude and the average charge registered discharges also increase by decreasing the temperature.

Experimental Design Methodology proves to be an effective tool in the analysis of the partial discharges evolution in mixed dielectric structures composed of impregnated polypropylene of Jarylec. The methodology presented in this paper is likely to provide a deeper insight into other processes. Mathematical models have allowed the quantification of the effect of each considered factors ( $T$ ,  $V_0$ ). The results show that the effect of temperature on the number of discharges is more important than the initial potential  $V_0$  is more significant in the range (-28 ° C to 0 ° C), the number of discharges increases significantly.

This result can be explained only the under cold conditions, the viscosity of the liquid increases. Consequently the lifetime expectancy of bubbles also increases; this explains the breakdown of the cell voltage levels lower than those obtained at room temperature. In this work it is shown that this method of measurement is multi-factorial and can be modeled by experimental design.

The present work can be extended by the study of discharges generated from other defects, such as the presence of several cavities. The main problem of this study is the use of capacitors (a) model that are closer to industrial capacitors. It would finally be interesting to use other impregnating liquids. This will allow to estimate the operation state of electric devices and their lifetime.

## 7. REFERENCES

- [1] Kreuger F.H., 1989. Partial discharges detection in high voltage equipment, Butterworth London, 15-18 .
- [2] Atkins J.M., DeVre M.W., Reed C.W & Kennedy W.N., 2013. Partial discharge and breakdown studies in model gas transformer windings, Gaseous Dielectrics III, 517-521.
- [3] Suzuki H., Aihara K., Okamoto T., 2004. Complex Behaviour of a Simple Partial Discharge Model, A Letters Journal Exploring the Frontiers of Physics, Vol. 66 (1), 28-34.
- [4] Hammal R., 1998. Partial discharges in all-film of capacitors impregnated, Thesis of doctoral, University Joseph Fourier Grenoble, France, 5-20.
- [5] Nemamcha M., Gosse J.P & Gosse B., August 1994. Effect of discharges on impregnated polypropylene film. IEEE, Trans on Elec Insul, vol. 1 (4), 578-584.
- [6] Cavallini A., Montanari G.C., Ciani F., 2005. Analysis of partial discharge phenomena in paper oil insulation systems as a basis for risk assessment evaluation, in Proc, IEEE, Int Conf on Dielectric Liquids (ICDL), Portugal, 241-245.
- [7] Daniel Guillen., Gina Idarraga-Ospina., Enrique Mombello., June 2014. Partial discharge location in power transformer windings using the wavelet Laplace function, Electric Power Systems Research, Vol. 111, 71-77;
- [8] Tabti B., Mekideche M.R., Plopeanu M.C., Dumitran L.M., Herous L., Dascalescu L., 2010. Corona-charging and charge decay characteristics of nonwoven filter media, IEEE Trans Ind Appl., vol. 46, 634-640.
- [9] Herous L., Nemamcha M., Remadnia M & Dascalescu L., 2009. Factors that Influence the Surface Potential Decay on the thin film of Polyethylene Terephthalate, Journal of Electrostatics; Elsevier, Vol. 67, Issue 2+3, 198-202.
- [10] Dervos C., Bourkas P.d., kayafos E.A & Stathopoulos I.A., 1990. Enhanced Partial Discharges due to temperature increase in the combined system of a solid liquid dielectric, IEEE Trans on Elect Insula, vol. 25, 3.
- [11] Zeller H.R., 1987. Breakdown and prebreakdown phenomena in solid dielectric, IEEE Trans elect Insul, vol. 22, 115.
- [12] Karagiannopoulos C.G., 2007. A model for dielectrics experiencing partial discharges under high electric fields, J. of Electrostatics, vol. 65 (8), 535-541.
- [13] Frigon N.L & Mathews., 1996. Practical guide to experimental design., Wiley, new York.
- [14] Goupy J., 1999. Experimental design for answer of surface, Dunod, Paris.
- [15] Remadnia M., Nemamcha M., Herous L., & Dascalescu L., 2011. Decay of the Electrical Potential at the Surface of Corona charged Uniforms layers of HIPS Granules, IEEE Transactions on Dielectrics and Electrical Insulation. Vol. 18 (2), 579-587.
- [16] Montgomery D. C., 2004. Design and Analysis of Experiments, 6th ed. New York: Wiley.
- [17] Eriksson L., Johansson E., Kettaneh-Wold N., Wikstöm C., and Wold S., 2000. Design of Experiments.

Principles and Applications. Umeaa, Sweden: Umetrics.  
Vol 15 (5), 495-496.

[18] Smili K., Herous L., Nemancha M., 2011.  
Experimental Investigation on evolution of partial  
discharge in polypropylene films impregnated with  
jarylec. JEE, vol. 11 (2) 4.

[19] Jarylec<sup>®</sup> high voltage dielectric fluids by Arkema  
2009. [www.arkema.com](http://www.arkema.com), 1-4.