

**The Role of Ethical Leadership on Job Performance**  
**-a study based on the Faculty of Economics, Commercial and Management**  
**Sciences - Tahri Mohamed Bechar University Algeria -**

دور القيادة الأخلاقية في الأداء الوظيفي – دراسة حالة كلية العلوم الاقتصادية، التجارية وعلوم التسيير بجامعة

طاهري محمد بشار الجزائر

**Dr. Elhazzam Mohammed<sup>1</sup>, Aissaoui Fatma<sup>2</sup>**

<sup>1</sup> Tahri Mohamed University, Laboratory of Study Economics & Development Local in South West of Algeria - Bechar (Algeria), elhazzam.mohamed@univ-bechar.dz

<sup>2</sup> Tahri Mohamed University, Laboratory of Study Economics & Development Local in South West of Algeria - Bechar (Algeria), aissaoui.fatma@univ-bechar.dz

**Received:** 05/03/2022

**Accepted:** 30/03/2022

**Published:** 31/03/2022

**Abstract:**

The aim of this study is to investigate the role of Ethical leadership (Ethical sensitivity, Integrity, Justice) on Job performance in Faculty of Economics, Commercial and Management Sciences of Tahri- M Bechar University - Algeria. The study method is descriptive statistics analysis. The population of study consisted up of all the teaching staff of the faculty, which their number is (84) teachers and sample size was determined by 48 teaches which is equivalent to (57.14%). In order to tested the hypotheses, the parametric tests of Pearson correlation and hierarchical regression in Statistical Package for the Social Sciences (SPSS) were used. The study results showed that the role of ethical leadership on Job performance is significant and all hypotheses were confirmed.

**Keywords:** Ethical leadership; Ethical sensitivity; Integrity; Justice; Job performance.

**JEL Classification Codes:** C12, C42, I23.

ملخص:

الهدف من هذه الدراسة هو استكشاف دور القيادة الأخلاقية (الحساسية الأخلاقية، النزاهة، العدالة) في الأداء الوظيفي في كلية الاقتصاد، العلوم التجارية علوم التسيير بجامعة طاهري محمد، بشار - الجزائر. أسلوب الدراسة وصفي-تحليلي، حيث تكون مجتمع الدراسة من جميع أعضاء هيئة التدريس بالكلية والبالغ عددهم (84) استاذًا، تم تحديد حجم العينة بـ 48 استاذًا أي ما يعادل (57.14%). لاختبار الفرضيات تم استخدام اختبارات معاملات الارتباط بيرسون والانحدار في الحزمة الإحصائية للعلوم الاجتماعية (SPSS). أظهرت نتائج الدراسة بوجود دور للقيادة الأخلاقية في الأداء الوظيفي بكلية الاقتصاد، العلوم التجارية علوم التسيير بجامعة طاهري محمد، بشار - الجزائر، كما تم تأكيد جميع فرضيات الدراسة.

كلمات مفتاحية: القيادة الأخلاقية، الحساسية الأخلاقية، النزاهة، العدالة، الأداء الوظيفي.

تصنيفات JEL: C12, C42, I23.

**Corresponding author:** Elhazzam Mohammed, e-mail: mhazzam@gmail.com

## **Introduction:**

Today, the challenges facing organizations are increasing, especially in light of technological progress, the information revolution, the conflict of values, and in light of the new globalization, which requires organizations to face these challenges efficiently and effectively to reach their goals. To keep up with these changes and challenges successful leaders who are capable of change and innovation, and have the ability to solve problems and make decisions in appropriate situations must be prepared. With the end of the twentieth century and the beginning of the new millennium, a new trend emerged in global economic organizations, followed by a similar trend in educational organizations, calling for abandoning the traditional concept of leadership based on hierarchy, guardianship, and authority of the center, and adopting new leadership patterns and models, that encourage collaborative work, and participation in making Decision, attention to subordinates and promoting their growth. All this within an ethical and human framework in which upgrading the job performance of the organization

## **1-2 Study Questions (RQ):**

Success remains the goal of any organization. This is the goal that can only be achieved if the workers are satisfied. This objective can be determined by certain factors such as the leader who will create the conditions for commitment and individual and collective performance.

Considering the importance of the role of ethical leadership on work performance, the following two questions can be formulated to express the research problem:

**RQ1:** Is there any association between ethical leadership and job performance in Faculty of Economics, Commercial and Management Sciences of Tahri- M Bechar University - Algeria?

**RQ2:** Is there a role for ethical leadership on job performance? in Faculty of Economics, Commercial and Management Sciences of Tahri- M Bechar University - Algeria?

## **1-3 Study Objectives**

The main purpose of this study was to examine the role of Ethical leadership (Ethical sensitivity, Integrity, Justice) on Job Performance in the Faculty of Economics, Commercial and Management Sciences of Tahri-M Bechar University- Algeria, and from the questionnaire and the results are discussed the following objectives.

- To determine the level of availability of ethical behavior in the respondent Faculty.
- To determine teachers' view of ethical leadership in Faculty.
- To determine the level of improvement of performance in the respondent Faculty.
- To assess the role of (Ethical sensitivity, Integrity, Justice) on Job performance in Faculty.

## **1- Literature Review:**

### **1-1 Ethics and Ethical leadership**

Previous literature related to the subject of this research has been reviewed in order to provide a scientific background.

#### **1-1-1 Ethics**

In today's world, ethics is an increasingly important component and point of discussion. So, leadership with ethics is very important for understanding, development, and recognition. Learning about ethical leadership is critical. Among the responsibilities of a leader in the design of ethical behavior in the organization, so that integrity, ethical behavior, and ethics are

the key to a great leader. Ethics is a part of every decision a leader must make, and the ethical integrity of a leader guides every choice. (Northouse, 2004) According to (Mihelič, Lipičnik , & Tekavčič, 2010, p. 32) It is concerned with describing and prescribing moral requirements and behaviors, which suggests that there are acceptable and unacceptable ways of behaving that serve as a function of philosophical principles. Ethical behavior is defined as behavior that is morally accepted as “good” and “right” as opposed to “bad” or “wrong” in a given situation Ethics is the code of values and moral principles that guides individual or group behavior with respect to what is right or wrong.

### **1-1-2 Leadership**

Leadership in any organization plays an important role in continuous economic growth, (Wilmot & Hocker, 2001) it is defined as a process whereby an individual influences a group of individuals to achieve a common goal. (Northouse, 2004) According (Mihelič, Lipičnik , & Tekavčič, 2010, p. 32) leadership is the art of persuading a follower to want to do the things, activities, that the leader sets as goals. The role of leaders is therefore in the process of directing the individual’s behavior towards the desired goal. Leaders vary depending on the individual leadership style that stems from personality characteristics The role of leaders is therefore in the process of directing the individual’s behavior towards the desired goal. Leaders vary depending on the individual leadership style that stems from personality characteristics.

### **1-1-3 Ethical leadership**

There has been a great interest in the terms of leadership in the organizations. Further, there are conflicting definitions of leadership and researchers generally define leadership depending on their individual perspectives. We have surveyed ethical leadership because of growing interest in the development and promotion of ethical leadership in organizations. have defined ethical leadership as “the demonstration of normatively appropriate conduct through personal actions and interpersonal relationships, and the promotion of such conduct to followers through two-way communication, reinforcement, and decision-making”. (Brown, Trevino, & Harrison, 2005, p. 120)

Ethical leadership is a concept that appears to be uncertain and includes various components. Instead of perceiving ethical leadership as preventing people from carrying out inappropriate acts, authors suggest that one should view it as enabling people to do the right thing. This concept has emerged which specifically focuses upon moral and ethical aspects of leadership behavior. According to (Eleftheria , 2015, p. 25). it is based primarily on the Aristotelian approach to ethics and morals and uses inquiry, the "Socratic" method, to analyze and discuss the dilemmas imposed on education by socio-political-economic challenges. modern, which requires a special way of dealing and making decisions The work of a leader is both intellectual and moral, his decisions must be intellectual and moral and cannot be taken in isolation. Ethical leadership must be able to identify when a decision has moral consequences, and it must then employ ethical decision-making modes that consider more than mere bottom-line results, understand the full consequences of utilitarian decision-making

that may not fully account for the social costs of a decision. (Sama & Shoaf, 2002) and choose to do the right thing consistently. According to (Brown, Trevino, & Harrison, 2005, p. 120) ethical leadership can be the demonstration of normatively appropriate conduct through personal actions and interpersonal relationships, and the promotion of such conduct to followers through two-way communication, reinforcement and, decision-making.

Ethical leadership, as defined by (Brown, Trevino, & Harrison, 2005, p. 120), captures employees' perceptions of ethical behavior inferred from the leader's conduct. More specifically, ethical leadership is defined as "the demonstration of normatively appropriate conduct through personal actions and interpersonal relationships, and the promotion of such conduct to followers through two-way communication, reinforcement, and decision making". To act in a normatively appropriate manner is to act consistently with general expectations regarding how leaders should behave in a work context. For example, "normatively appropriate" implies that leaders are fair, honest, principled, and trustworthy in taking responsibility for their own actions, and use rewards and punishments where appropriate to hold subordinates responsible for their actions. At the same time, normatively appropriate conduct is deliberately vague because expectations regarding correct behavior depend on the organizational context.

#### **1-1-3-1 Ethical sensitivity**

Ethical sensitivity involves the ability to interpret the reactions and feelings of others. It involves being aware of alternative courses of action, knowing cause–consequence chains of events in the environment, and how each could affect the parties concerned. As such, it involves empathy and role-taking skills. For individuals being socialized to professional practice, ethical sensitivity involves the ability to see things from the perspective of other individuals and groups (including other cultural and socio-economic groups), and more abstractly, from legal, institutional, and national perspectives. Thus, it includes knowing the regulations, codes, and norms of one's profession, and recognizing when they apply. (Bebeau, 2002, p. 283)

#### **1-1-3-2 Integrity**

Integrity refers to the quality of having a strong moral purpose, according to (Furrow, 2005, p. 136) integrity is the extent to which our various commitments form a harmonious, intact whole. Coherence on this view is between the variety of obligations one has embraced, and the consistency each has with the other.

#### **1-1-3-3 Justice**

Ethical leaders are concerned about the issues of equality, fairness, and justice. They make it a priority to treat their subordinates in an equal manner. Justice demands that leader place issues of fairness at the center of decision-making. As a rule, no one should receive special treatment or special consideration, except when his or her particular situation demands it. (Ndedi & Nisabwe, 2020, p. 5)

### **1-2 Job Performance**

Raising performance in organizations is one of the crucial issues managers should consider, Studies have defined job performance as a multi-dimensional concept that includes both task performance as well as contextual performance. According to (Motowidlo &

Harrison , 2008) Job performance is defined as a certain behavior that organizations expect an individual to carry out. Job performance is defined as it focuses directly on employee productivity by assessing the number of units of acceptable quality produced by an employee in a manufacturing environment, within a specific time period. cited that job performance is a skill possessed by an employee to perform various jobs related to job needs. (Malkanathi & Ali, 2016)

### 1-3 Ethical leadership and Job Performance

The relationship between job performance and other variables has been studied by many researchers because it is very important in management, In contrast, there are few studies that have focused on the relationship between ethical leadership and job performance, and although ethical leadership is also essential, it did not get the largest share, as the main focus is on leadership in organizations, leadership styles and traits of managers with little emphasis on ethics The ethical principles of leaders such as credibility, transparency, service to others, fairness and power-sharing, which have an important and critical role in the performance of employees. (Peachey & Wells, 2011)

## 2- Study Model and Hypotheses Development:

### 2-1 Study Model

Fig (1): Research model

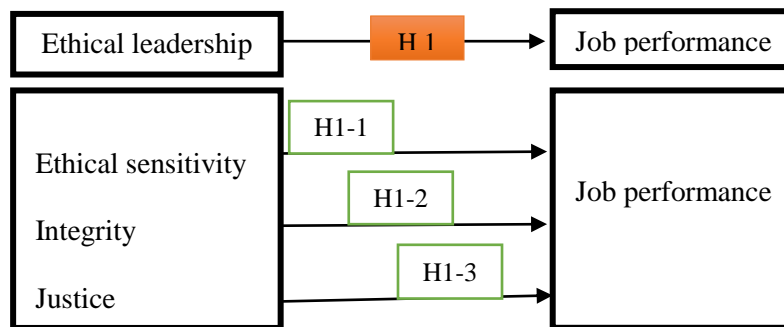

### 3-2 Study Hypotheses

In order to achieve the objectives designed for this study, the following research hypotheses are stated based on the revelation in the review of literature concerning Ethical leadership and Job performance

**H1:** There is a significant relationship between ethical leadership and Job performance in the Faculty of Economics, Commercial Sciences and Management Science - Tahri M, Bechar University.

The main hypothesis can be divided into three hypotheses according to the ethical leadership variables as follows:

**H1.1:** There is a significant relationship between Ethical sensitivity and Job performance

**H1.2:** There is a significant relationship between Integrity and Job performance

**H1.3:** There is a significant relationship between Justice and Job performance.

### 3- Study Methodology:

This part presents a summary of information regarding the methodology that was adopted and used in this study. The part also describes the research design, target population, data collection instruments, and the techniques for data analysis that was used.

#### 3-1 Methodology

In order to realize this study, a methodology consisting of a combination of primary and secondary data has been used. A considerable amount of secondary data is gathered from existing literature about the role of Ethical leadership on Job performance. For empirical analysis of the study, a questionnaire designed on a 5-point Likert scale ranging from strongly disagree to strongly agree was used to collect data from the teachers in the Faculty of Economics, Commercial Sciences and Management Science - Tahri M, Bechar University, Algeria. A questionnaire was divided into three parts:

**First part:** comprising four (4) items seeking demographic data, which is Gender, Age, -Job rank, Experience.

**Second part:** consist of five-thirty (30) items of data regarding Ethical leadership, 10 items for each of the variables (Ethical sensitivity, Integrity, Justice)

**Third part:** consist of five-ten (15) items requesting information about job performance Pearson correlation statistical technique and regression analysis was applied to the data and were possessed with SPSS (Statistical Package for the Social Sciences).

#### 3-2 Sample

A sample is a finite part of a statistical population whose properties are studied to gain information about the whole. When dealing with people, it can be defined as a set of respondents (people) selected from a larger population for the purpose of a survey, which ensures that conclusions from the study can be generalized to the entire population. For this study, a Random sampling technique was used for collection of data, The population of the study consisted up of all the teaching staff of the faculty, which number is (84) teachers, and the sample size was determined by 48 teaches which is equivalent to (57.14%).

#### 3-3 Reliability and Validity

Before applying statistical tools, test the reliability of the scale. Cronbach's alpha is the most widely used method. Reliability is the degree to which measures are free from error and therefore yield consistent results<sup>16</sup>. The closer the reliability coefficient gets to 1.0, the better it is, and those values over .80 are considered as good. Those values in the 0.70 are considered acceptable and that reliability value less than 0.60 is considered to be poor.

**Table (1): Reliability value of the Scale**

variable	Nb. of Items	Cronbach's Alpha ( $\alpha$ )
Ethical sensitivity	10	.827
Integrity	10	.909
Justice	10	.838
Job Performance	15	.758

Source: study data 2021

**3-4 Demographic Characteristics of Respondents**

The sample characteristics are summarized as following in the tables below.

**Table (2): Gender composition of respondents**

Gender	Frequency	Valid Percentage (%)
Male	10	20.8
Female	38	79.2
Total	48	100.0

Source: study data 2021

As shown above in the table 2, a total of 48 responded to the questionnaire in this study. The majority of the respondents (79.2%) to the study were females, while the rest representing 20.8% are male

**Table (3): Age distribution of respondents**

Age	Frequency	Valid Percentage (%)
20-30	6	12.5
31-40	9	18.75
41-50	19	39.6
+ 50	14	29.15
Total	48	100.0

Source: study data 2021

The data obtained from the questionnaire, shown in Table 3, reveals that 19 respondents between 41 to 50 years of age representing 39.6%, formed the majority. 14 respondents, each above 50 years of age representing 29.15% and 9 respondents each between 31 to 40 years of age representing 18.75% respectively. 6 respondents each between 20 to 30 years representing 12.5%.

**Table (4): Job rank of respondents**

Job rank	Frequency	Valid Percentage (%)
lecturer professor (B)	4	8.4
lecturer professor (A)	41	85.4
professor	3	6.2
Total	48	100.0

Source: study data 2021

The data obtained from the questionnaire, shown in Table 4 presents the job rank of respondents. The results in the table reveal that respondents from lecturer professor (A) formed the majority with 41, representing 85.4%, 4 from the lecturer professor (B) representing 8.4%, 3 from the professor category representing 6.2%, 12 from sales representing 10%, and 9 from accounts representing 7.5%.

**Table (5): Experience of employment**

Experience (Years)	Frequency	Valid Percentage (%)
5-10	13	35.4
11-20	20	41.7
+ 15	15	22.9
Total	48	100.0

Source: study data 2021

As illustrated in Table 5 above, the results indicate that 35.4% of respondents have experience in the 5 to 10 year range, 41.7% of the sample have worked for 11 to 20 years and 22.9% have more than 15 years of experience. These results indicate that the respondents had an important experience.

#### 4- Findings and Discussion:

The following tools frequencies, means, percentages, standard deviation, Pearson correlation, and regression analysis, were used as descriptive analysis to meet the study questions and to test the main hypothesis and its branches. Main hypothesis: There is a significant relationship between ethical leadership and Job Performance in the Faculty of Economics, Commercial Sciences and Management Science - Tahri M, Bechar University – Algeria.

##### 4-1 Correlation

**Table (6): descriptive statistics and construct correlations**

	Variables	N	Mean	S.D	PER	E.S	INT	JUS
<b>1</b>	<b>Job Performance</b>	48	3.42	1.04	1			
<b>2</b>	<b>Ethical Sensitivity</b>	48	3.41	1.03	.641**	1		
<b>3</b>	<b>Integrity</b>	48	3.38	1.21	.656**	.523**	1	
<b>4</b>	<b>Justice</b>	48	3.52	.917	.468**	.389**	.589**	1

\*Correlation is significant at the 0.05 level (2-tailed)

\*\*Correlation is significant at the 0.01 level (2-tailed)

Source: study data 2021

The results in Table 6 show the descriptive statistics and correlation between dependent and independent variables.

Pearson correlation for Job Performance with Ethical sensitivity, Integrity, Justice, ( $r=0.641, 0.656, 0.468$   $p<0.01$ ) respectively show that there is a positive relationship between Job Performance and Ethical sensitivity, Integrity, Justice.

Correlation coefficient values show a moderate and strong relationship between variables respectively, Ethical sensitivity and Integrity, Justice, ( $r= 0.523, 0.389$   $p<0.01$ ) show a respectively positive relationship between Ethical sensitivity, Integrity, Justice.

The correlation coefficient value confirms a strong relationship between variables. Pearson correlation for Integrity and Justice ( $r=0.589, p<0.01$ ) shows a positive relationship between Integrity and Justice.



#### 4-2 Regression

**Table (7): Regression Coefficients**

Variables	Unstandardized Coefficients		Standardized Coefficients	t	Sig.
	B	Std. error	Beta		
<b>Constant</b>	1.243	.094		13.30	.000
<b>Ethical Sensitivity</b>	.087	.012	.246	6.607	.000
<b>Integrity</b>	.064	.011	.235	6.261	.000
<b>Justice</b>	.073	.012	.212	5.216	.000

Dependent Variable : Job Performance

**Source:** study data 2021

The results of regression analysis conducted to test the research model between Ethical leadership and Job Performance is as shown in table 7. The model explains the association between Job Performance and Ethical leadership (Ethical Sensitivity, Integrity, Justice).

The constant job Performance will be 1.243, also that a unit increase in Ethical Sensitivity will cause a 0.087 increase in Job Performance, that a unit increase in Integrity will lead to an increase in Job Performance by 0.064. It was also found that a unit increase in Justice will lead to an increase in Job Performance by 0.073.

Correlation and Regression results above show the association of variables among each other and positive relationships. Thus, we accept the hypotheses of the research.

#### **Conclusion:**

This study examined the role of ethical leadership (Ethical sensitivity, Integrity, Justice) on job performance in the Faculty of Economics, Commercial and Management Sciences of Tahri- M Bechar University - Algeria. It confirms that Ethical leadership (Ethical sensitivity, Integrity, Justice) influences job performance. Based on a result from Pearson Correlation Analysis, it showed that there was a positive relationship between the dependent variable job performance and the independent variables ethical leadership (Ethical sensitivity, Integrity, Justice). This indicates the important role of ethical leadership in job performance.

The present study was conducted on teachers of the Faculty of Economics, Commercial and Management Sciences. researchers recommend that similar studies be conducted on teachers of other faculties and conducting qualitative studies to examine the other factors which are possible to affect teachers' performance.

#### **Limitations of the Study:**

This study was limited by other factors in that some respondents may have been biased or dishonest in their answers considering that they were all commenting on their leaders. More respondents would have been essential to increasing the representation of respondents in this study and allowed for a better check of consistency of the information given. The sample size of our study represents another limitation. However, despite the above limitations, the findings presented in this paper have important implications.

**Recommendation:**

Ethics and moral values are considered the most important factors of the organization. Ethical leadership has an influence on employee performance. Hence, a primary contribution of this study is that efforts in promoting ethical leadership practices in the university must start and be perceptible at the top of the organization. Another important contribution of this study is that employees may not play the so commonly thought important roles in behaving ethically in their workplaces, for this reason, ethical leaders endowed with the mind of behaving ethically may be needed to a greater extent to make a difference in employee performance. Indeed, an important aspect of the organization's poor performance that must be obviated hinges on the promotion of the practices of ethical leadership.

**Bibliography List:**

1. Bebeau, M. (2002). The Defining Issues Test and the Four Component Model: contributions to professional education. *Journal of Moral Education*, 31(3), 271-295.
2. Brown, M., Trevino, L., & Harrison, D. (2005). Ethical leadership: A Social Learning Perspective for Construct Development and Testing. *Organizational Behaviour and Human Decision Processes*, 97, 117-134.
3. Brown, M., Trevino, L., & Harrison, D. (2005). Ethical Leadership: A social learning perspective for construct development and testing. *Journal of Organizational Behavior and Human Decision Processes*, 97, 117-134.
4. Eleftheria , A. (2015). The challenge of ethical leadership university courses: preparing leaders for an uncertain, turbulent and divert future. *Revista Lusófona de Educação*(30), 15-41.
5. Furrow, D. (2005). *Ethics: Key concepts in philosophy*. New York: Continuum International Publishing Group.
6. Malkanthi, S., & Ali, M. (2016). Impact of job design on employees' performance in people's banks of Ampara district. 5th Annual International Research Conference. Oluvil.
7. Mihelič, K., Lipičnik , B., & Tekavčič, M. (2010). Ethical Leadership,. *International Journal of Management & Information Systems*, 14(5), 31-42.
8. Motowidlo, S., & Harrison , J. (2008). *Job Performance*. Kell Rice University.
9. Ndedi , A., & Nisabwe, F. (2020). Revisiting the Literature Review on Ethical Leadership and Humanocracy. Retrieved from <https://ssrn.com/abstract=3704240>.
10. Northouse, P. (2004). *Leadership theory and practice* Thousand Oaks. California: Sage Publications, Inc.
11. Peachey, W., & Wells, E. (2011). Turnover intentions Do Leadership behaviors and satisfaction with the leader matter? *Team Performance Management*, 17(2), 23-40.
12. Sama, L., & Shoaf, V. (2002). Ethics on the Web: Applying Moral Decision-Making to the New Media. *Journal of Business Ethics*, 36 (1/2), 93–103.
13. Wilmot, W., & Hocker, J. (2001). *Interpersonal conflict*. New York: McGraw-Hill.